

Suburban RV FURNACES SERVICE MANUAL

DD-17DSI • DD-17DSIW
NT-12S/SE • NT-16S/SE • NT-20S/SE
NT-24SP • NT-30SP • NT-34SP
NT-40
P-30S/40
SF-20 • SF-25 • SF-30 • SF-35 • SF-42
SF-20F • SF-25F • SF-30F • SF-35F • SF-42F
SH-35 • SH-42
SH-35F • SH-42F
SHD-2542
SFV-35 • SFV-42
SFV-35F • SFV-42F

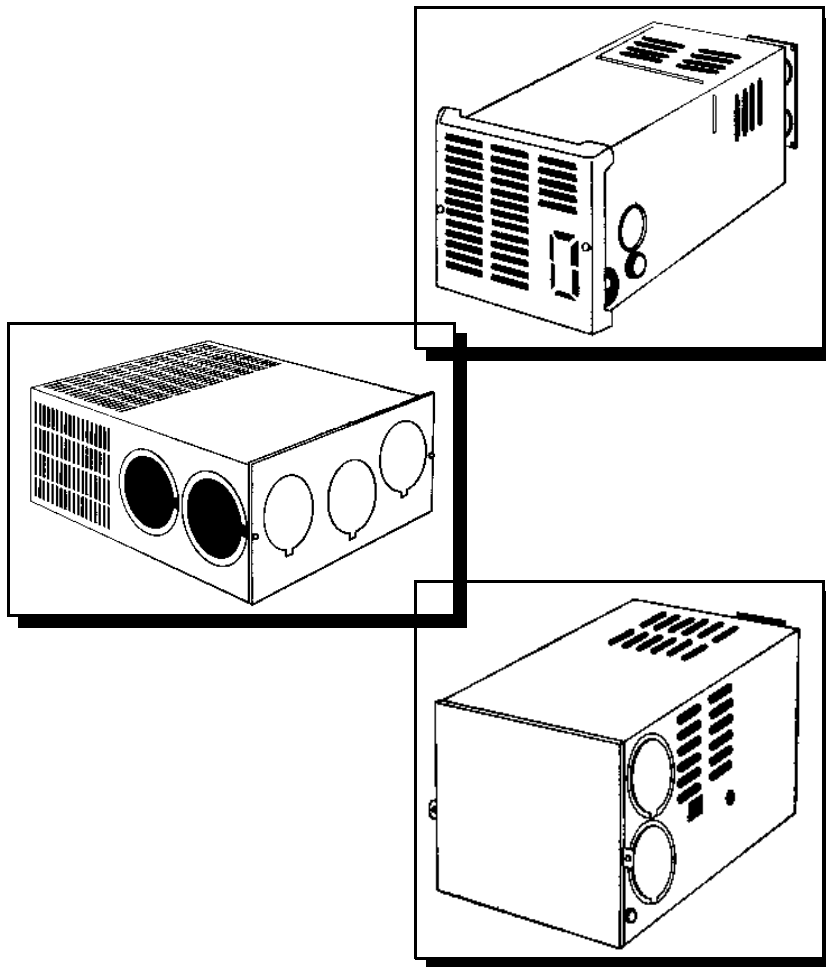

Suburban
Manufacturing Company

a division of AIRXCEL, Inc.

SUBURBAN MANUFACTURING COMPANY
676 Broadway Street
Dayton, Tennessee 37321
423-775-2131
Fax: 423-775-7015
www.rvcomfort.com
info1@suburbanmfg.com

TABLE OF CONTENTS

	Page
General Service Information	3
Furnace Spec Sheet	4
Installation	5
Vent Assembly Illustrations	6-16
Return Air Illustrations	16
Ducting Illustrations	17
Installation Requirements (DD, NT and P Model Furnaces)	18
Installation Requirements (SF, SH and SHD-2542 Model Furnaces)	19
Installation Requirement (SFV Model Furnaces)	20
Furnace Specifications (DD, NT and P Model Furnaces)	21
Furnace Specifications (SF, SFV, SH, and SHD-2542 Model Furnaces)	22
Sequence of Operation (Time Delay Relay Equipped Furnaces)	23
Sequence of Operation (Fan Control Module Board (520820) Equipped Furnaces)	24
Sequence of Operation (24 VAC Fan Control Module Board (520947)	25
Sequence of Operation (SHD-2542 Furnance)	26
Trouble Shooting Flow Chart (Furnaces Equipped with Time Delay Relay)	27
Trouble Shooting Flow Chart (Furnaces Equipped with Fan Control Module Board)	28
Service Hints, Diagnosis and Corrective Measures	
for Suburban 24-Volt AC Electronic Ignition Furnaces	29-30
Wiring Diagrams	30-34
Furnace Removal	35-36
SF, SH and SHD-2542 Electrode Gap Specifications & Positioning	37
NT and Park Model Electrode Gap Specifications & Positioning	38
Maintenance	39
Cautions & Safety Information	Back Cover

NOTE: Our service technicians are available to assist you in making repairs or parts replacements from 8:00 a.m. to 5:00 p.m. Eastern Standard Time, Monday through Friday (except holidays), by calling 423-775-2131 extension 7102. E-mail address: info1@suburbanmfg.com

GENERAL SERVICE INFORMATION

Suburban DYNATRIL furnaces installed in recreational vehicles are classified as Direct Vent Sealed Combustion Furnaces. A forced draft furnace utilizes a sealed combustion chamber which is vented to the outside atmosphere. The intake air for combustion is also taken from outdoors and is completely isolated from the room air. A motor is used to drive an impeller wheel to draw intake air into the chamber to support combustion and force the exhaust gases through the furnace chamber to the outside atmosphere. A second impeller wheel (driven by the same motor yet totally isolated from the combustion air) is used to circulate room air across the furnace chamber where it is heated. The blower then forces the hot air into the living area either through a duct system or through a front grille on the furnace cabinet on direct discharge models.

Suburban furnaces operate on 12-volt DC power which is supplied either by a 12-volt battery or a converter system. A recreational vehicle furnace that is specifically designed for "park model" trailers operates on 120 volts AC. These are designed and tested under the same standards as the 12-volt models.

Suburban forced draft combustion furnaces used in recreational vehicles are designed for use with Propane gas. Although a few recreational vehicle furnaces are approved for use with natural gas, one should never attempt to convert such a unit to natural gas unless the conversion is approved by the manufacturer of the furnace.

Gas Supply Pressure Requirements

Line Pressure:
Minimum 11" WC*, Maximum 14" WC
*WC - water column

Voltage Requirements

Voltage DC: 12 volt D.C.
Minimum 10.5 volts D.C., Maximum 13.5 volts D.C.

Service Tools Required

Manometer gauge/ U-Tube
Volt ohm meter capable of testing above 15 amps
Module board tester #641511
Gas leak detector **OR** approved leak check liquid
Assorted wrenches
Assorted hand tools
Safety glasses

Suburban RV FURNACES

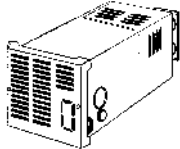
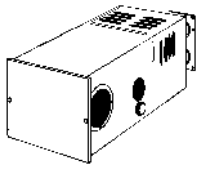
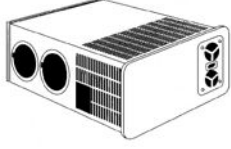
	12 VDC Direct Discharge	BTU/h Input	Height	Width	Depth	Ignition	Shipping Weight	
	NT-12SE	12,000	9 3/8"	9 3/8"	21-27 3/4"	Electronic	27	
	NT-16SE	16,000	9 3/8"	9 3/8"	21-27 3/4"	Electronic	27	
	NT-20SE	19,000	9 3/8"	9 3/8"	21-27 3/4"	Electronic	27	
	DD-17DSI	17,000	12"	10 1/2"	22-29"	Electronic	25	
	Accessories	Description						
	260197	Vent Kit 2" - 4" DD Models						
	260198	Vent Kit 4" - 6" DD Models						
	260199	Vent Kit 6" - 9" DD Models						
		12 VDC Ducted Furnaces	BTU/h Input	Height	Width	Depth	Ignition	Shipping Weight
NT-12S		12,000	9 3/8"	9 3/8"	22 3/4-29 1/2"	Electronic	27	
NT-16S		16,000	9 3/8"	9 3/8"	22 3/4-29 1/2"	Electronic	27	
NT-20S		19,000	9 3/8"	9 3/8"	23 3/8-30 1/8"	Electronic	27	
NT-24SP		24,000	12 1/2"	12"	23"	Electronic	40	
NT-30SP		30,000	12 1/2"	12"	23"	Electronic	40	
NT-34SP		34,000	12 1/2"	12"	23"	Electronic	40	
NT-40		40,000	12 1/2"	12"	23"	Electronic	42	
SF-20F		20,000	7 1/2"	17"	20"	Electronic	35	
SF-25F		25,000	7 1/2"	17"	20"	Electronic	35	
SF-30F		30,000	7 1/2"	17"	20"	Electronic	35	
SF-35F		35,000	7 1/2"	17"	20"	Electronic	35	
SF-42F		40,000	7 1/2"	17"	20"	Electronic	35	
SH-35F		35,000	9 1/4"	17"	20"	Electronic	40	
SH-42F		40,000	9 1/4"	17"	20"	Electronic	42	
SF-20*		20,000	7 1/2"	17"	20"	Electronic	35	
SF-25*		25,000	7 1/2"	17"	20"	Electronic	35	
SF-30*		30,000	7 1/2"	17"	20"	Electronic	35	
SF-35*		35,000	7 1/2"	17"	20"	Electronic	35	
SF-42*		40,000	7 1/2"	17"	20"	Electronic	35	
SH-35*		35,000	9 1/4"	17"	20"	Electronic	40	
SH-42*		40,000	9 1/4"	17"	20"	Electronic	42	
SHD-2542		25/40,000	9 1/4"	17"	20"	Electronic	44	
Accessories		Description						
6258ACW		*Door, Optional Access, Colonial White, Standard SF Models						
6258APW	*Door, Optional Access, Polar White, Standard SF Models							
6267ACW	*Door, Optional Access, Colonial White, Standard SH Models							
	120 VAC Park Model Furnaces	BTU/h Input	Height	Width	Depth	Ignition	Shipping Weight	
	P-40	40,000	12 1/2"	12"	23"	Electronic	46	
	Accessories	Description						
	050733	Duct Cover						
	050715	Duct Collar 4"						
	051240	Duct Collar 2"						
	280552	Rain Shield						
	062164	Bottom Duct Gasket, NT-24/30/34SP, NT-40, P40						
	070853	Bottom Duct Gasket, SF Models Except SF-42, (F)						
	520009	Bottom Duct Kit W/Gasket, NT-24/30/34SP, NT-40, P40						
520576	Bottom Duct Kit W/Gasket, SF Models Except SF-42, (F), SH35 (F)							
520753	Bottom Duct Kit W/Gasket and Door, SF-42, (F)							
520864	Bottom Duct Kit W/Gasket SH-42 (F) SHD-2542							

Wall Thermostats are included with All Models, except SF.
Vent Assemblies are included with all units, except DD.

INSTALLATION

There are several important aspects of the installation which will pertain to all Suburban forced draft furnaces, regardless of the model or the method in which they are installed. They are:

1. **Selecting a Location**
2. **Venting**
3. **Return Air**
4. **Ducting**

Refer to the furnace installation manual for all installation requirements.

Location and Installation- Locate the furnace near lengthwise center of the coach. Choose a location for installation out of the way of wires, pipes, etc. which might interfere with the installation. **Adhere to the minimum clearances from cabinet to combustible construction as listed in the installation manual for your specific furnace model.** Secure furnace cabinet to the floor of the coach using the holes provided in the furnace cabinet.

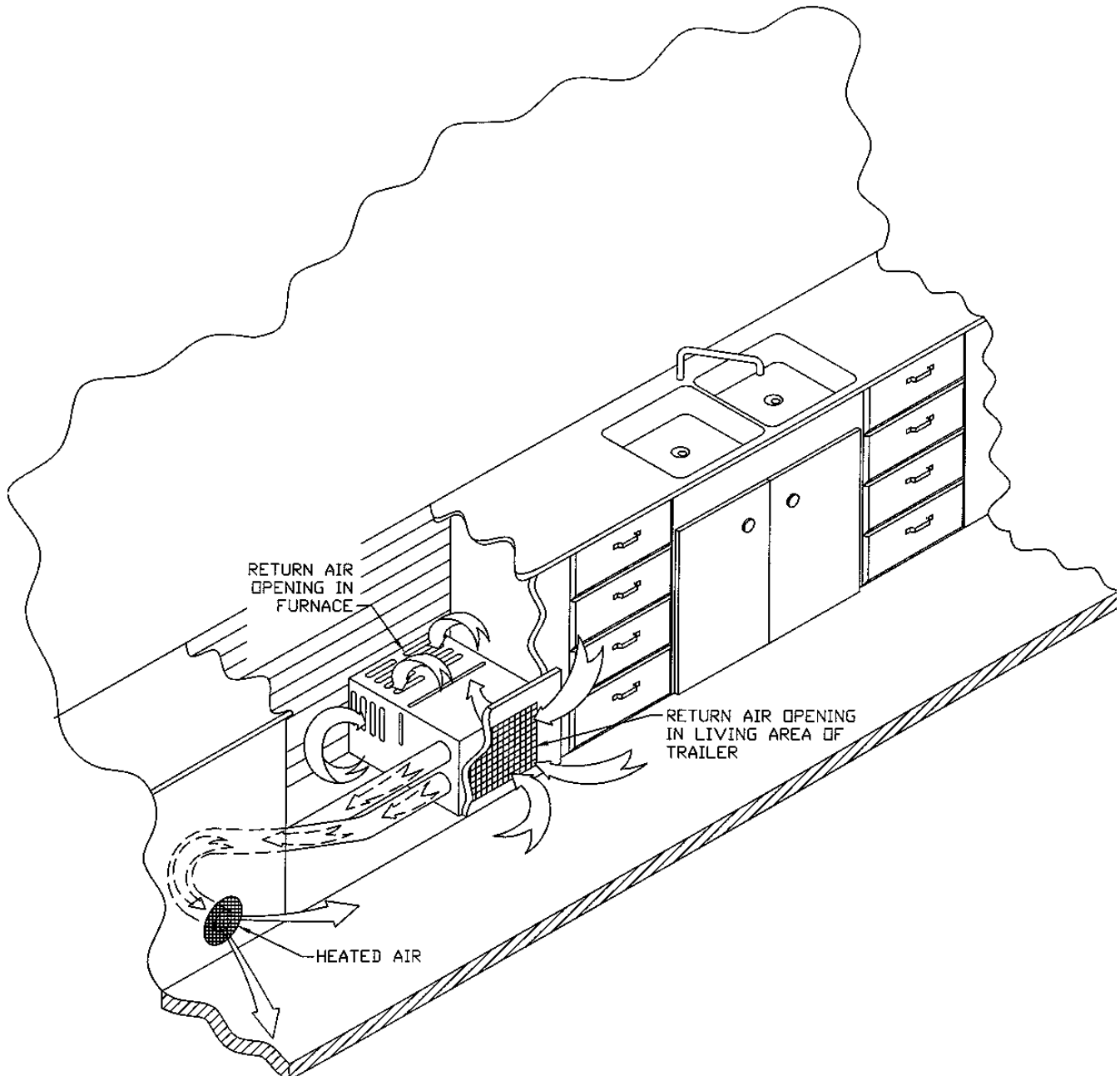

Figure 1

VENTING

Venting- By definition of a Direct Vent Sealed Combustion Furnace, it must be vented to the outside atmosphere and also draw combustion air from outdoors. Therefore, it is imperative that the vent be unobstructed and there must be a seal between the exhaust and intake (caulking). Refer to the vent assembly installation in the manual. The vent must be straight. There can be no offsets or turns in the vent. All vent tubes which connect to the furnace exhaust and intake must overlap a **minimum of 1/2" on intake, and 1 1/4" on exhaust.** Check your furnace model number for vent installation procedures. Vents cannot be altered as supplied from the factory.

VENT ASSEMBLY INSTALLATION (SF and SH SERIES)

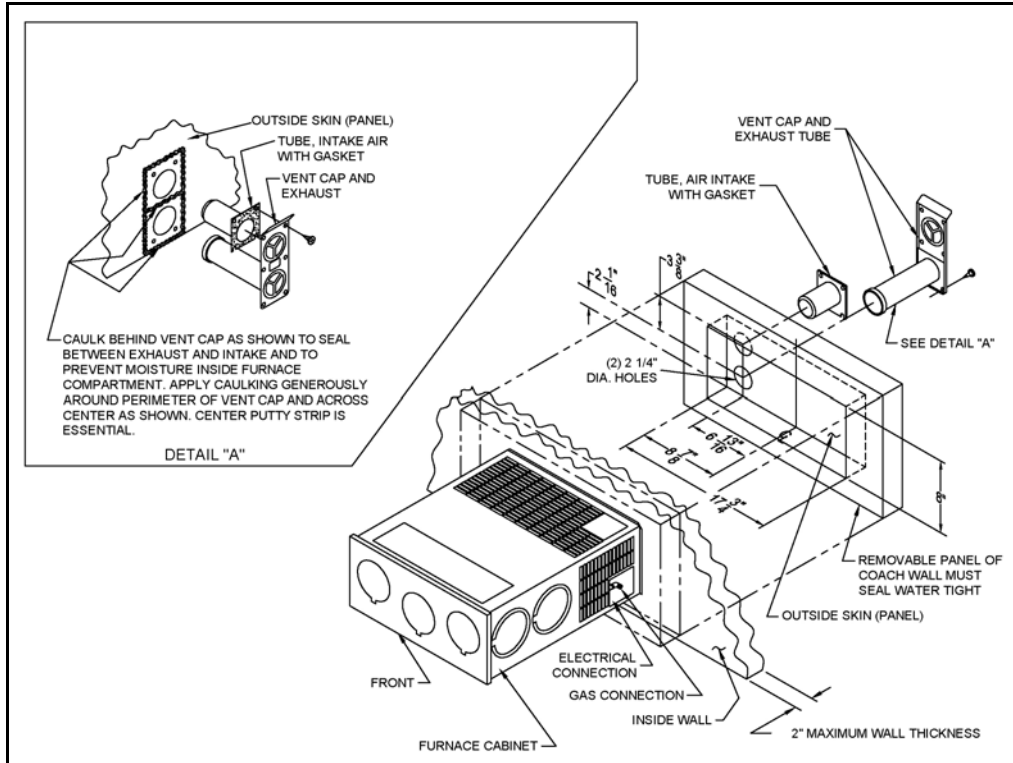

Figure 2
SF

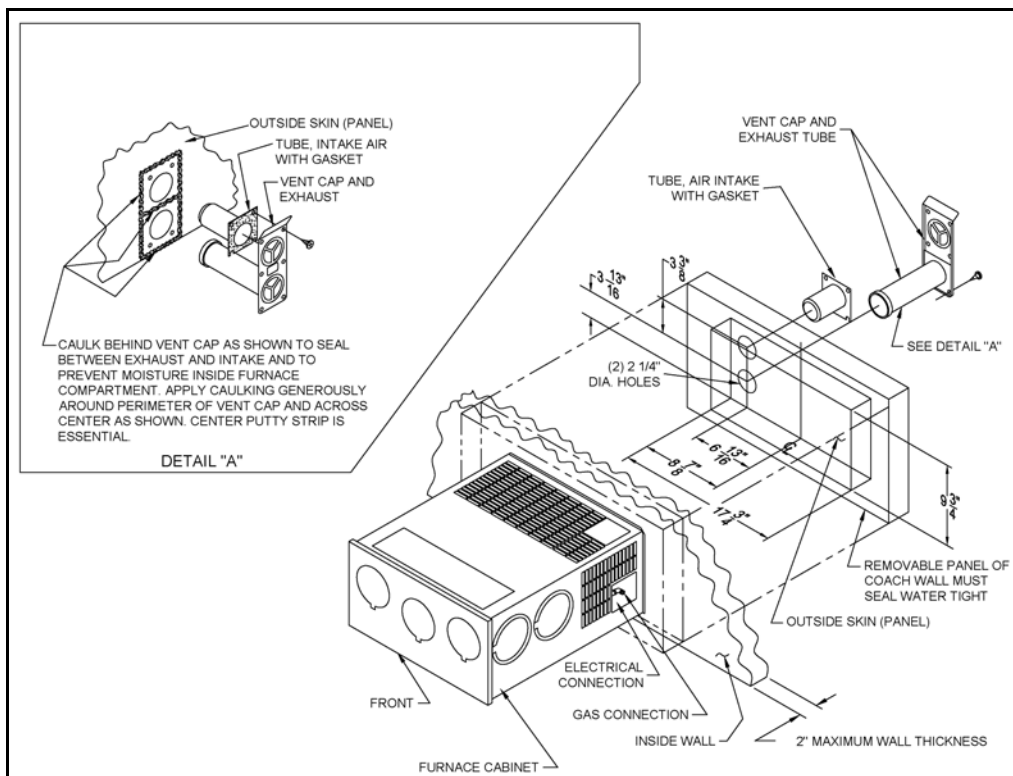

Figure 2A
SH

VENT ASSEMBLY INSTALLATION (SF and SH SERIES)

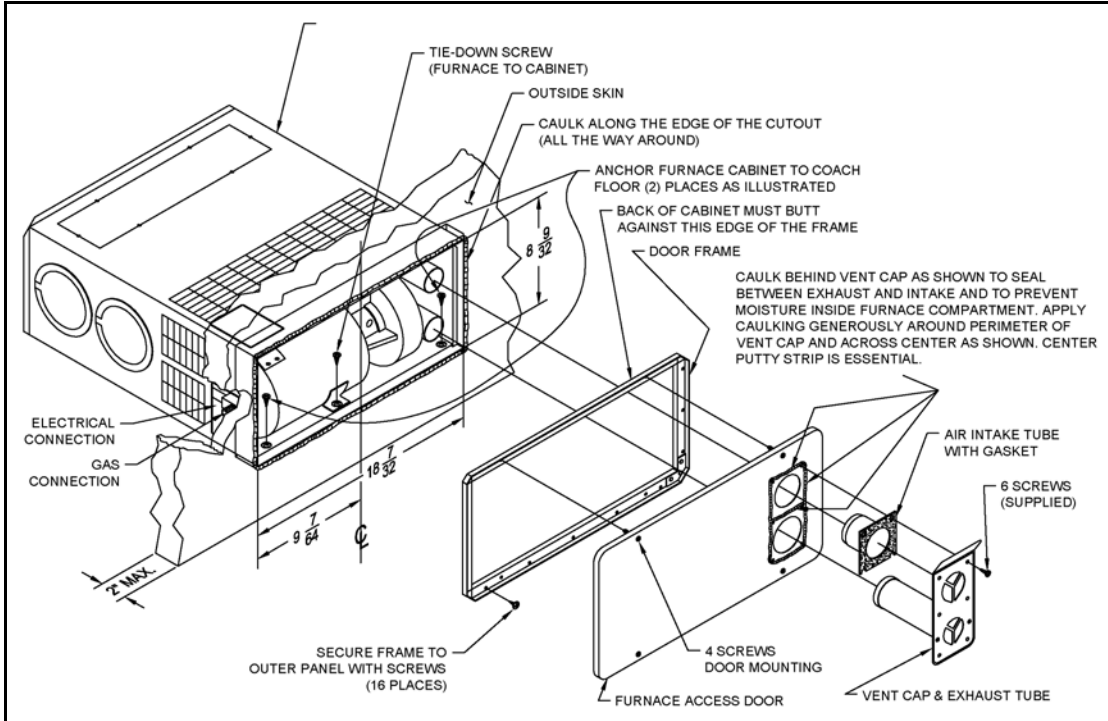

Figure 3
SF

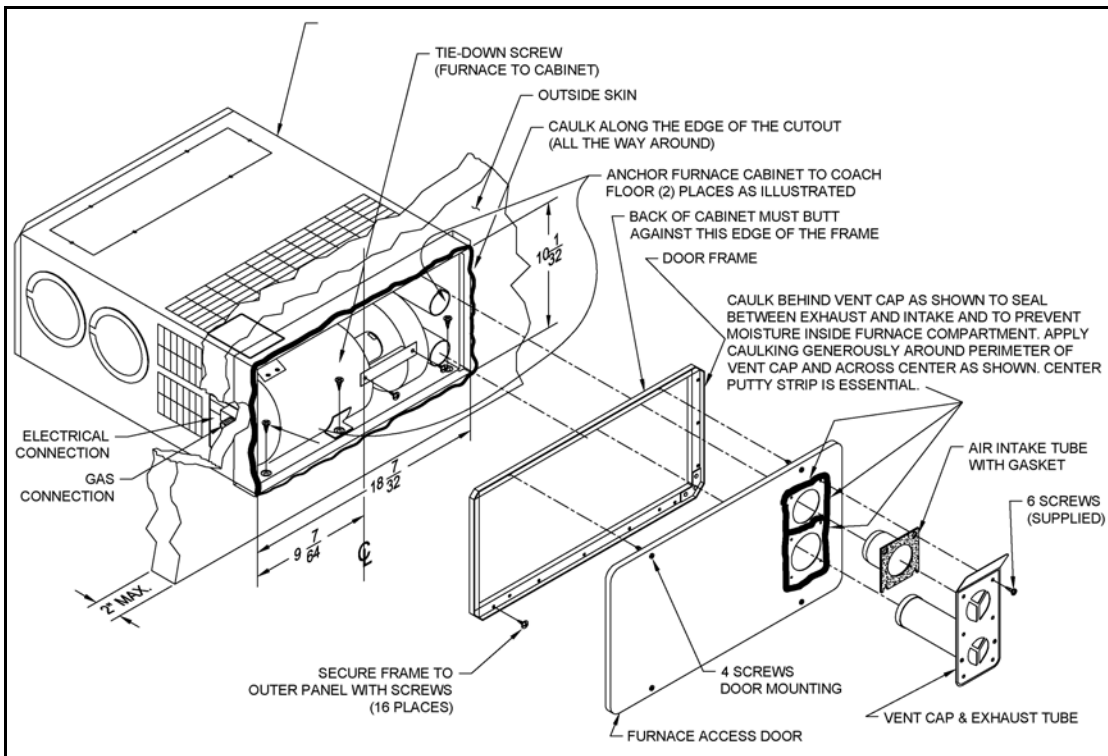

Figure 3A
SH and SHD-2542

VENT ASSEMBLY INSTALLATION (SF and SH SERIES)

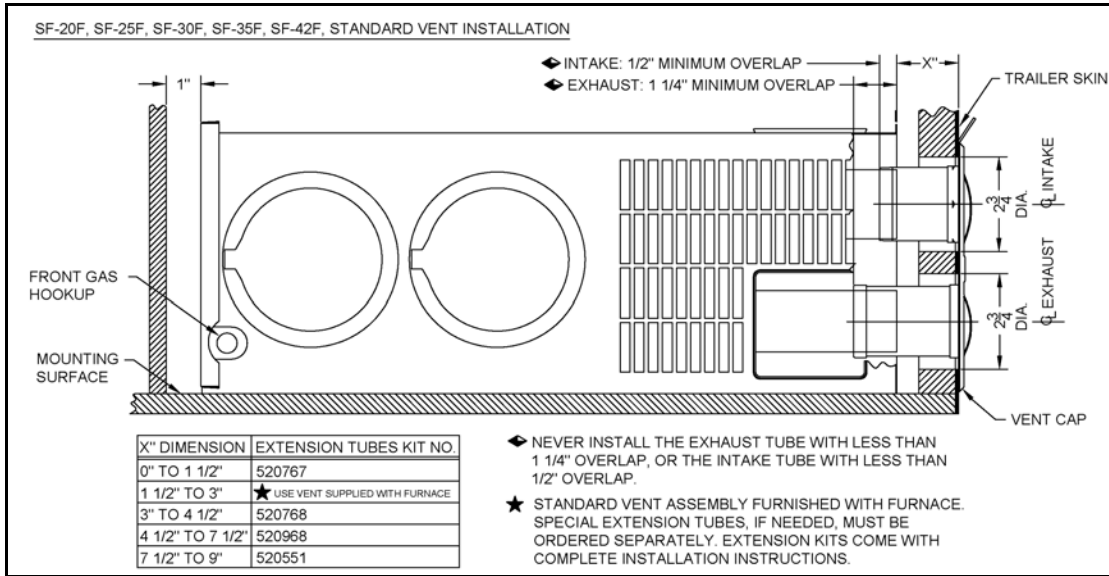

Figure 4
SF

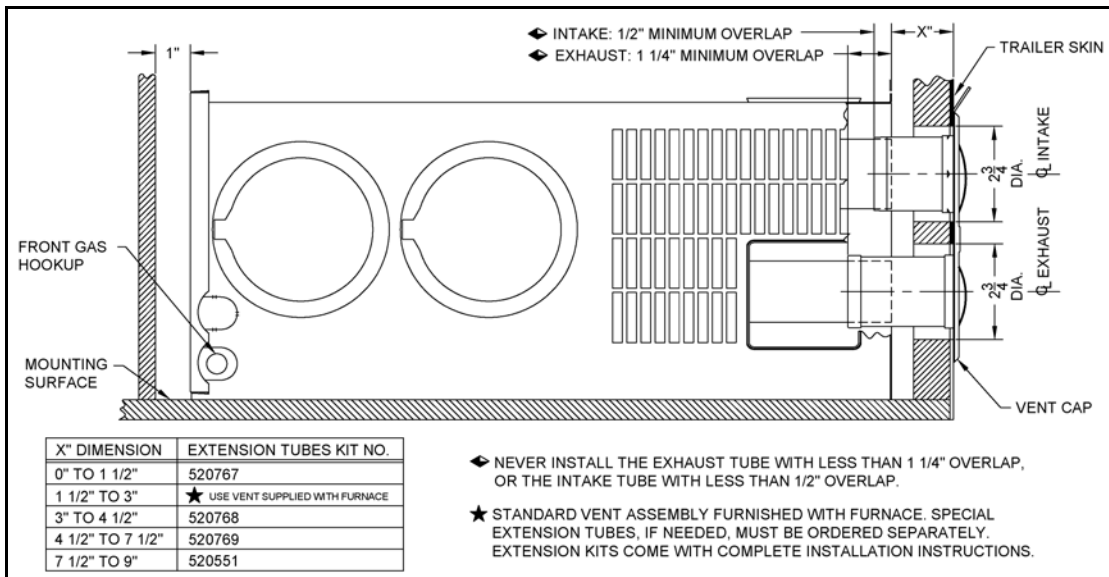

Figure 4A
SH

VENT ASSEMBLY INSTALLATION (SFV)

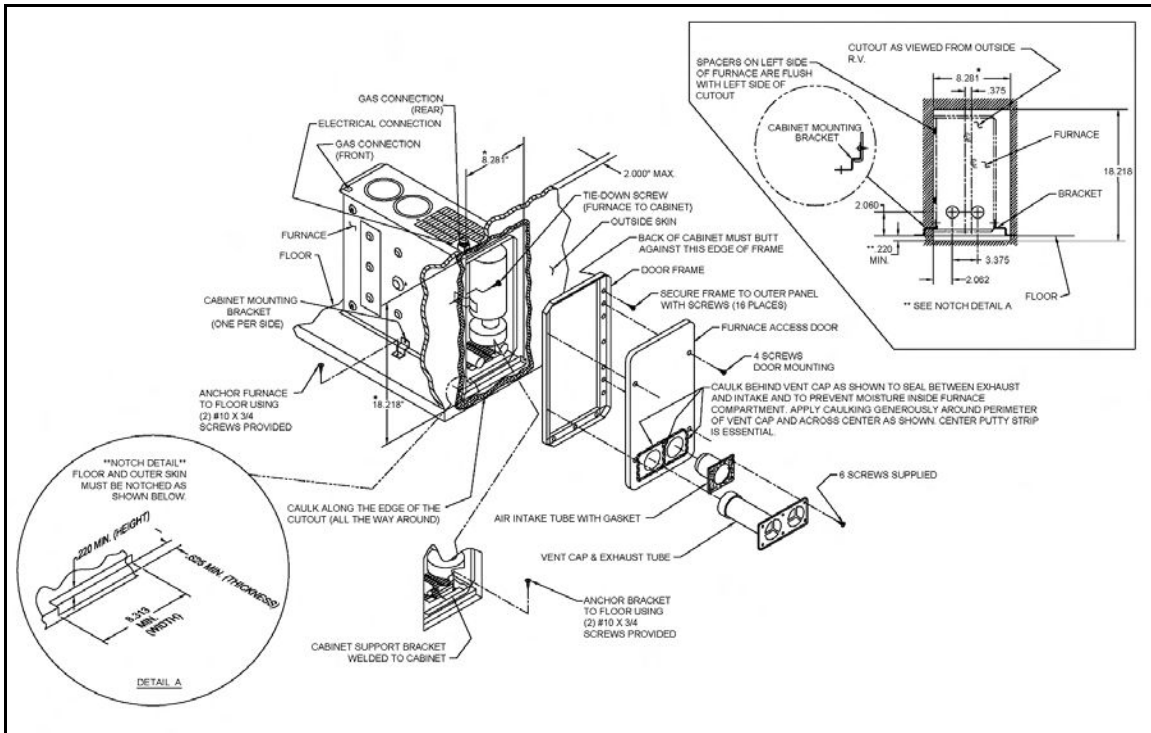

Figure 5

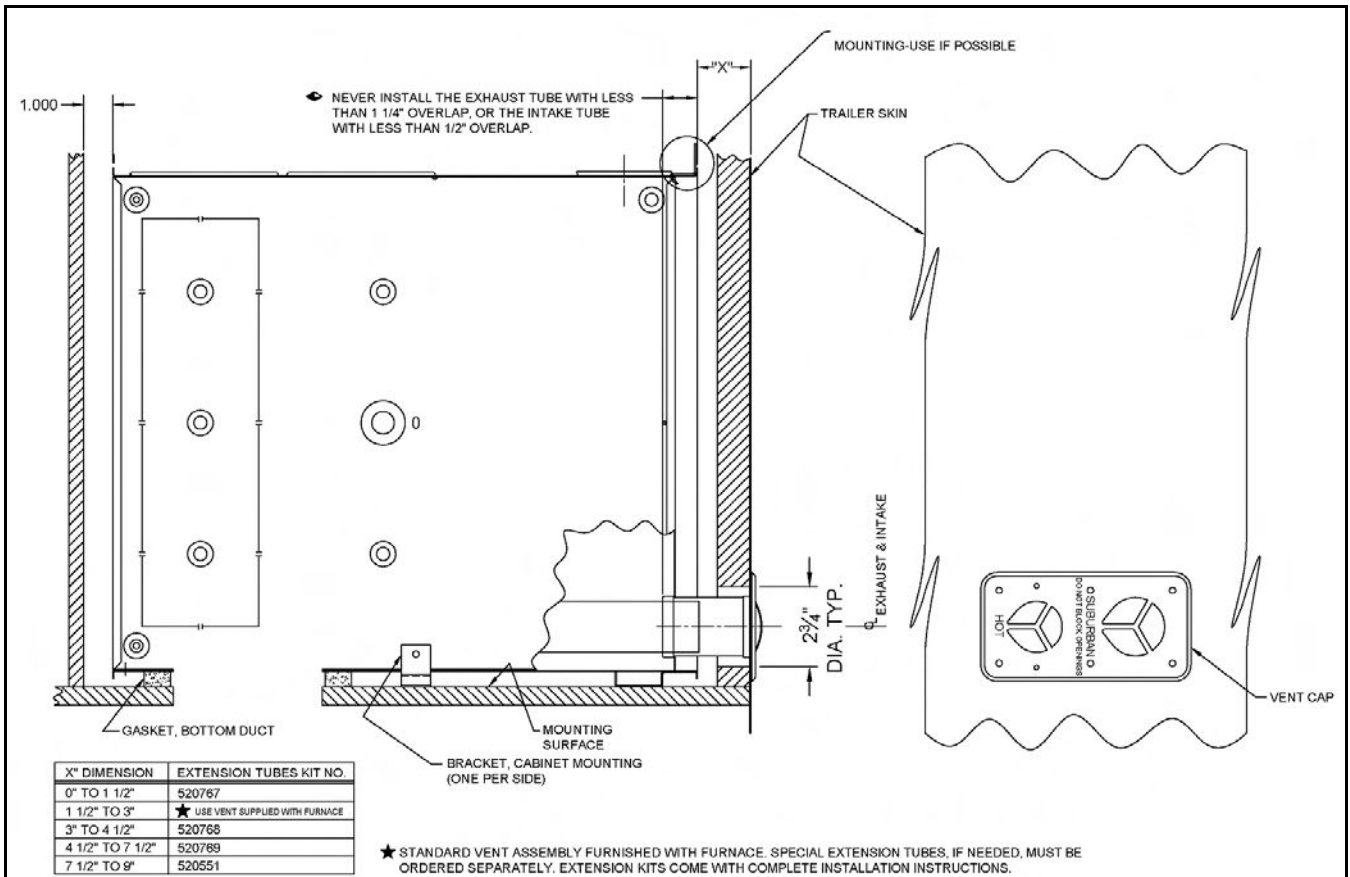

Figure 5A

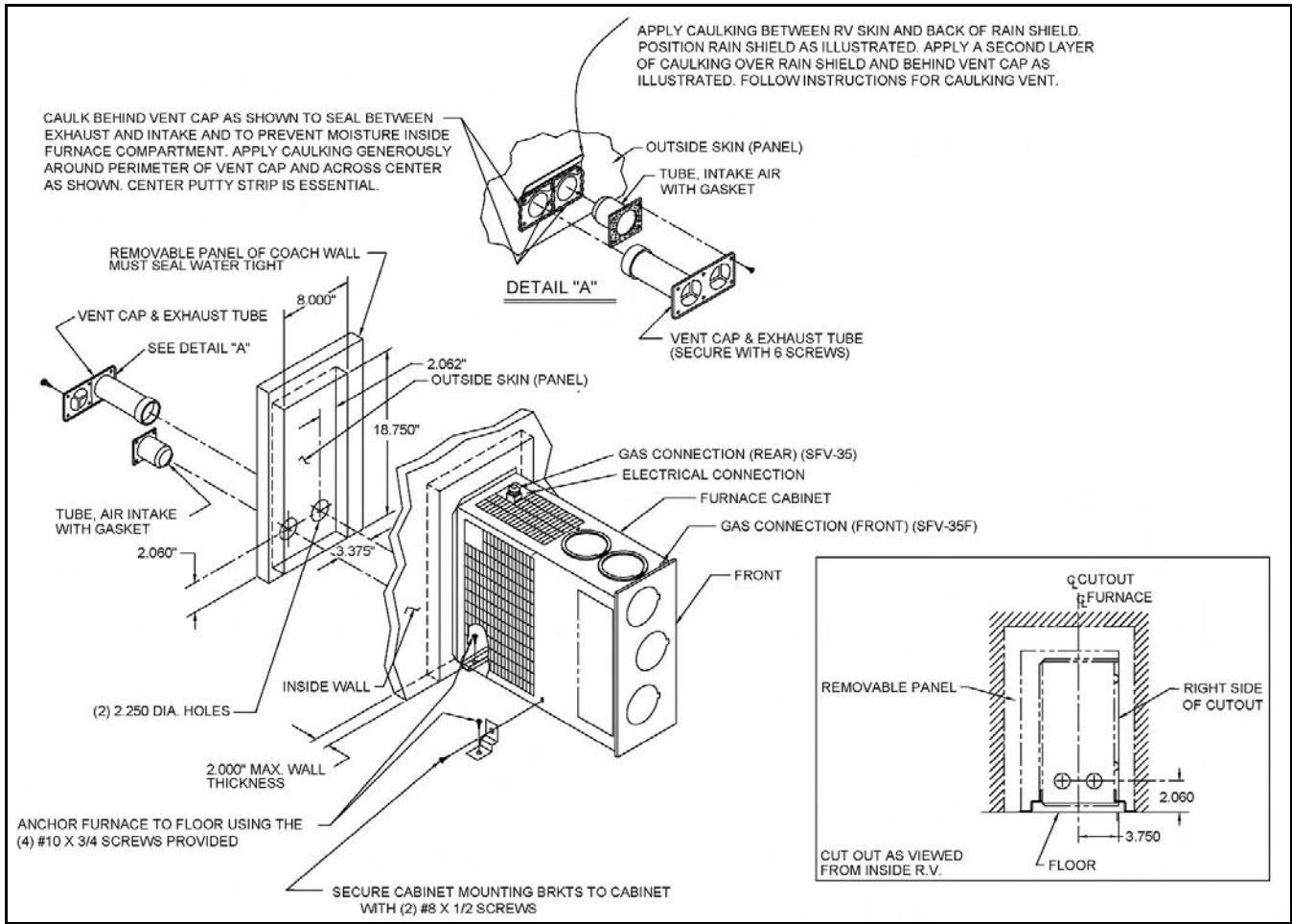

Figure 6

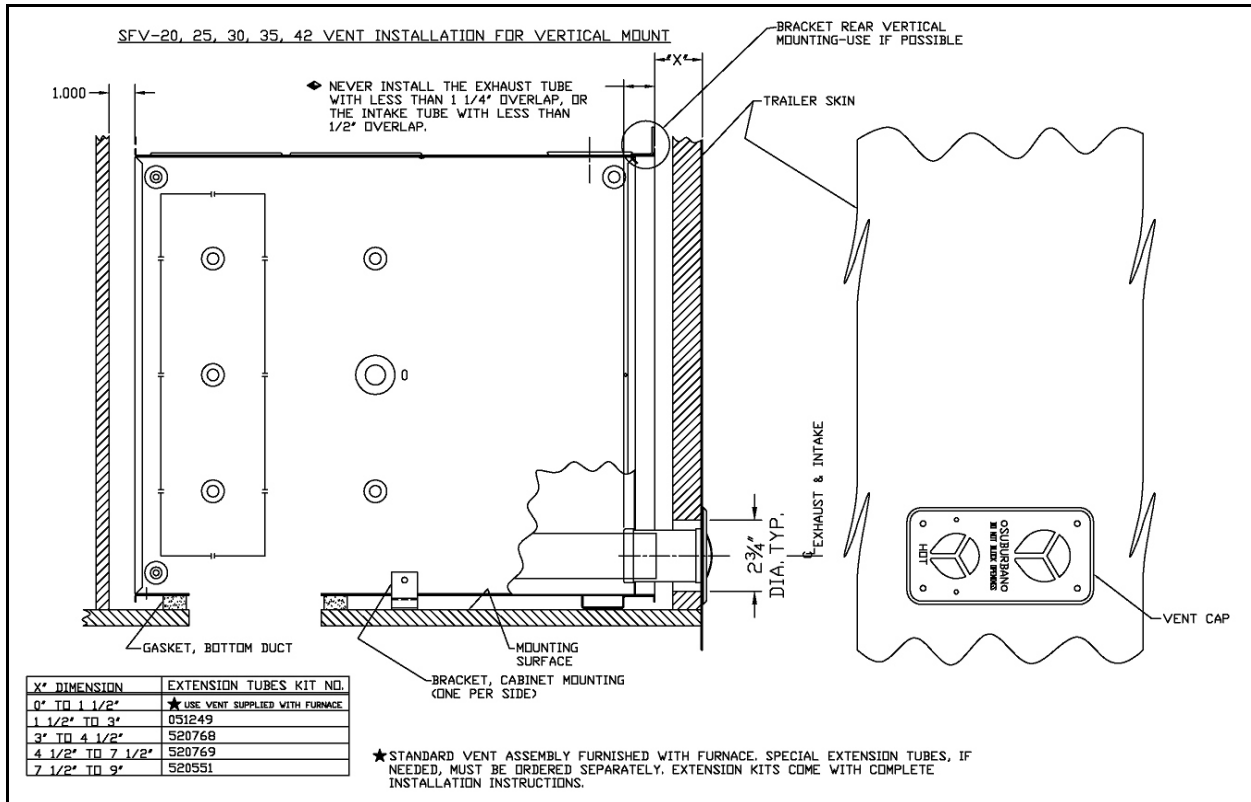
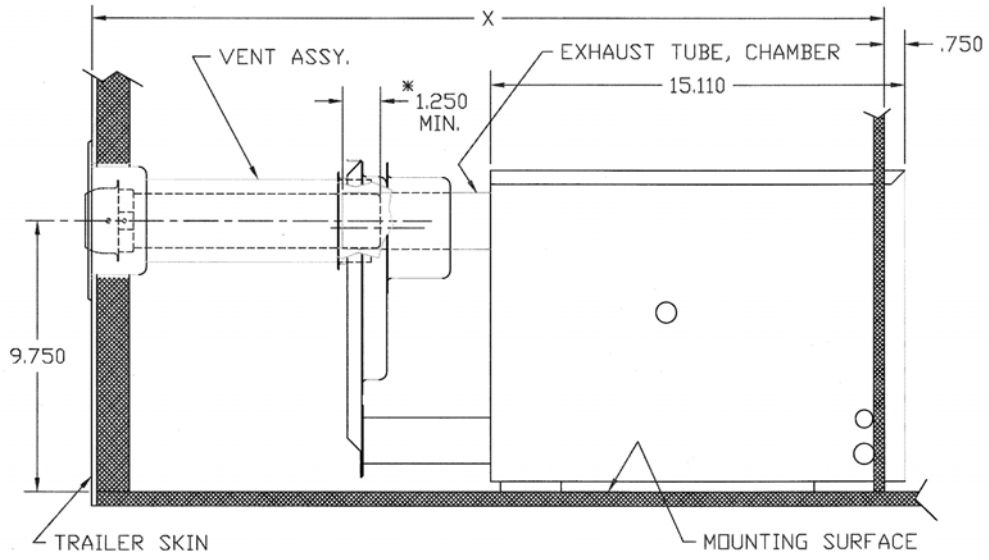

Figure 6A

VENT ASSEMBLY INSTALLATION (DD SERIES)

Note: Vent cap must be installed on DD furnace when bench testing.



PART NO.	VENT LENGTH	X DIMENSIONS
260197	5 7/8"	22" - 24 3/8"
260198	8 3/16"	24 3/8" - 26 5/8"
260199	10 1/2"	26 5/8" - 29"

* NOTE:
NEVER INSTALL VENT WITH LESS THAN 1.250" OVERLAP
BETWEEN CHAMBER EXHAUST TUBE & VENT ASSY.
EXHAUST TUBE.

Figure 7

VENT ASSEMBLY INSTALLATION (NT SERIES)

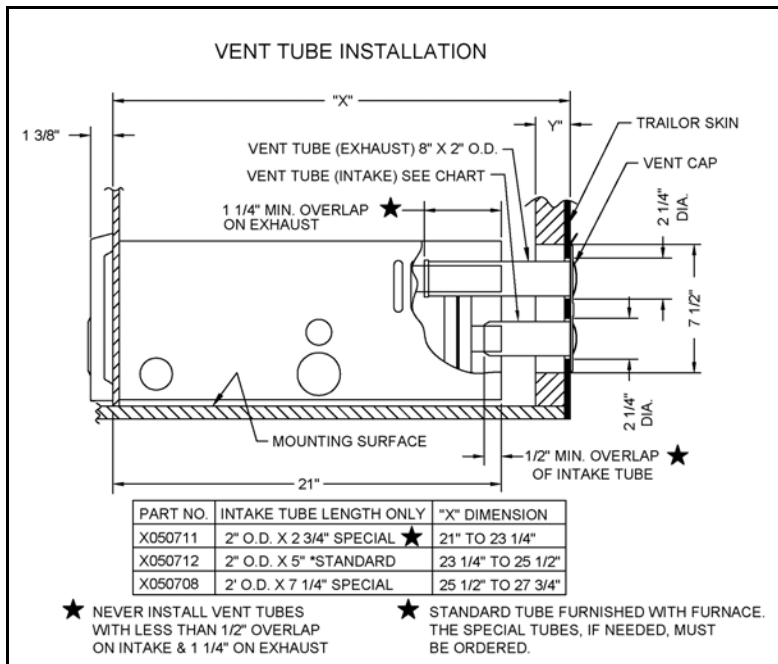

Figure 8
NT-12/16/20SE

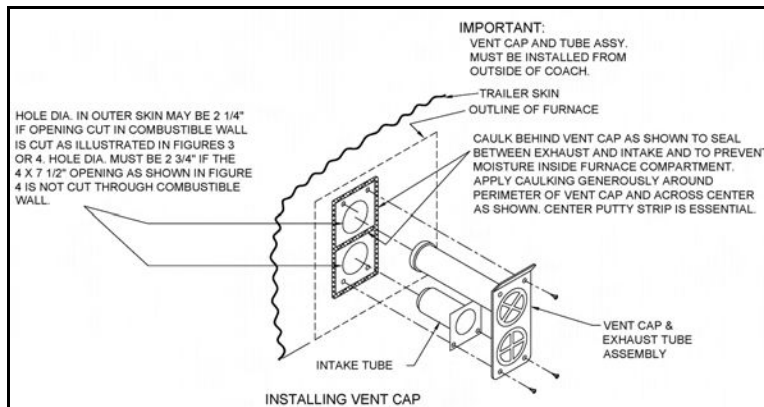

Figure 9
NT-12/16/20S and SE

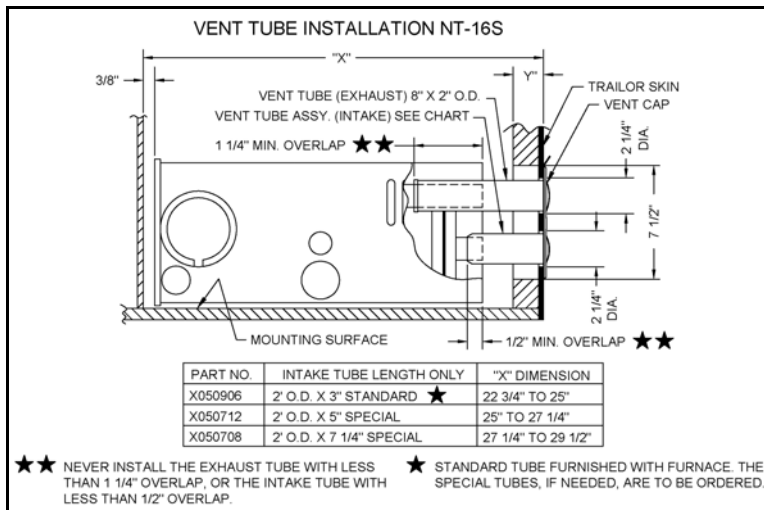

Figure 10
NT-12/16S

VENT ASSEMBLY INSTALLATION (NT SERIES)

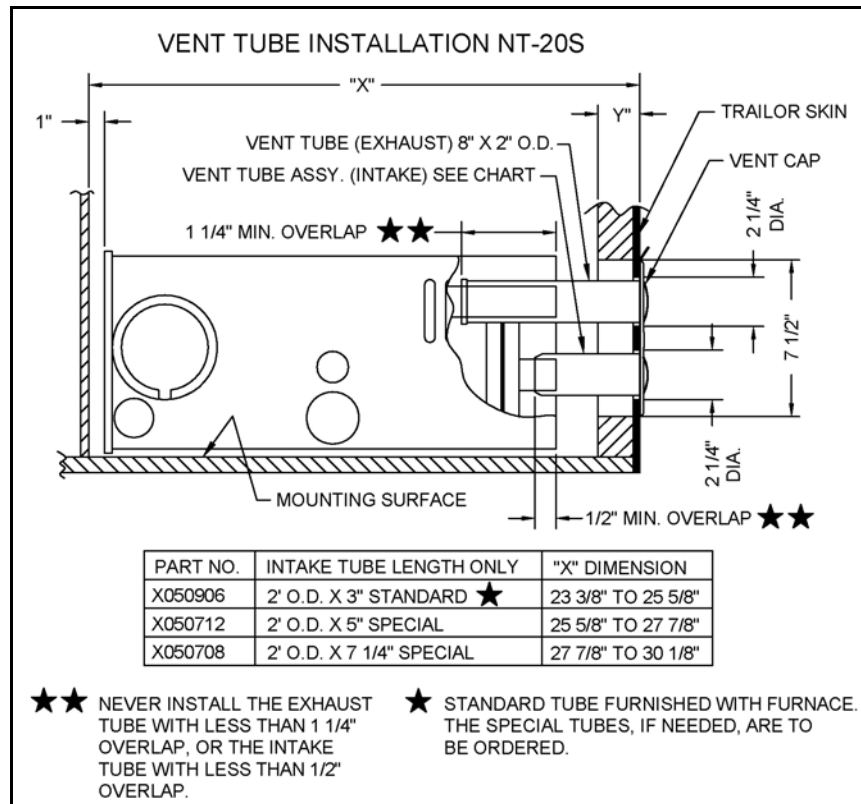

Figure 11
NT-20S

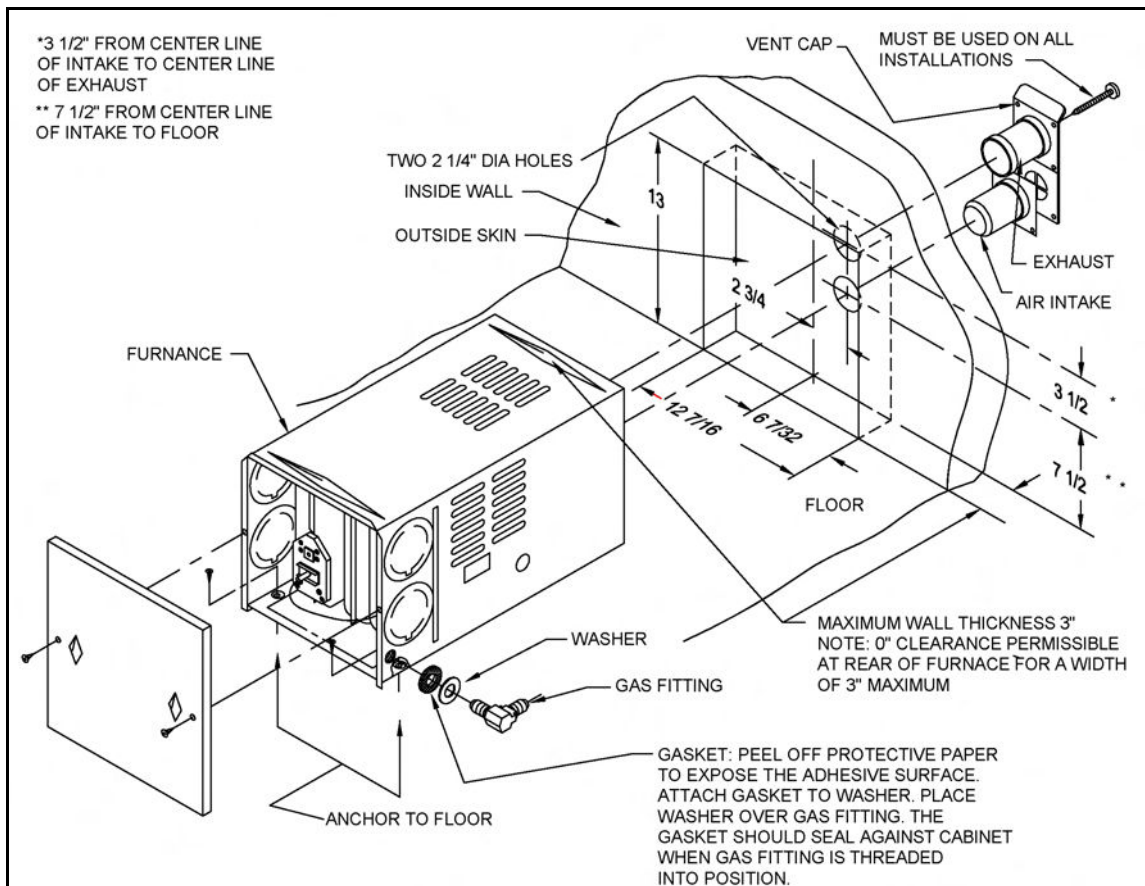

Figure 12
NT-24/30/34SP
P-30S

VENT ASSEMBLY INSTALLATION (NT SERIES)

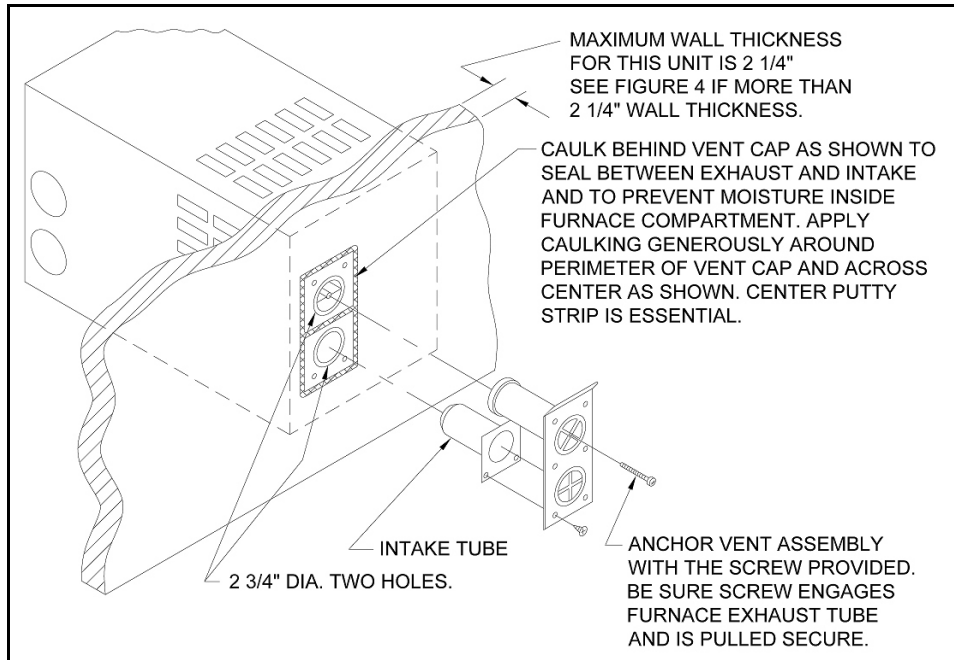

Figure 13
NT-24/30/34SP
P-30

EXTENSION TUBE KIT NUMBER	MIN./MAX. LENGTH (Extension Tube Range)
520498	2-1/4" to 3-1/8"
520499	3-1/8" to 4-7/8"
520500	4-7/8" to 7"
520501	7" to 9"

Figure 14
NT-24/30/34SP
P-30S

EXTENSION TUBE KIT NUMBER	MIN./MAX. LENGTH (Extension Tube Range)
520593	2-1/4" to 3-1/8"
520594	3-1/8" to 4-7/8"
520595	4-7/8" to 7"
520596	7" to 9"

Figure 15
NT-40
P-40

VENT ASSEMBLY INSTALLATION (NT-40 and P-40)

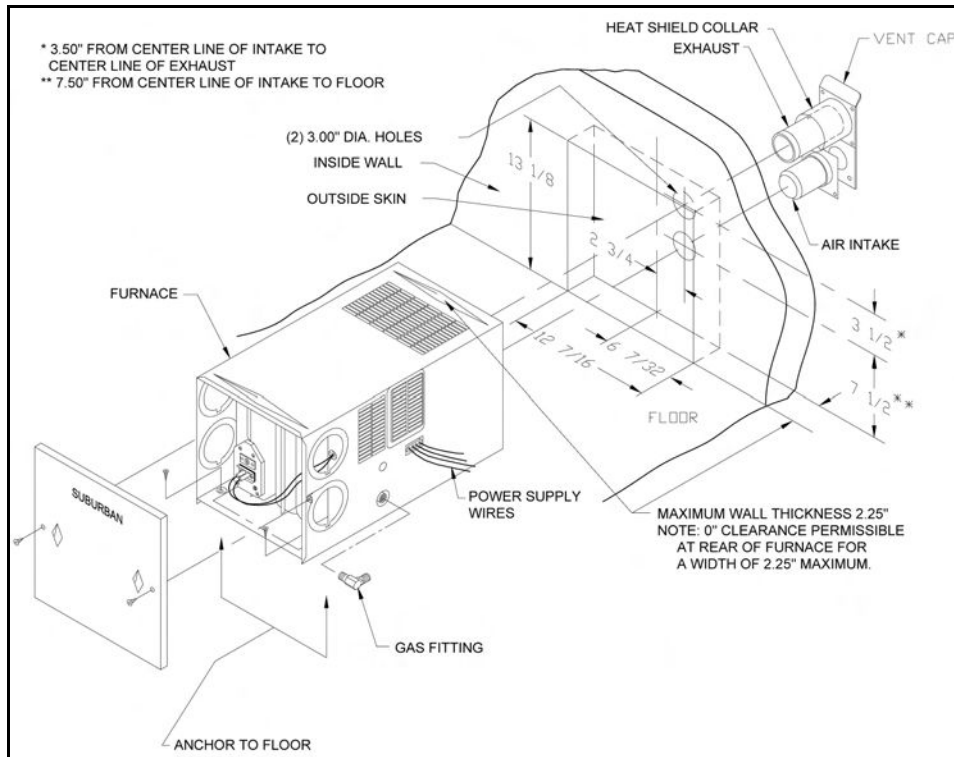

Figure 16
NT-40

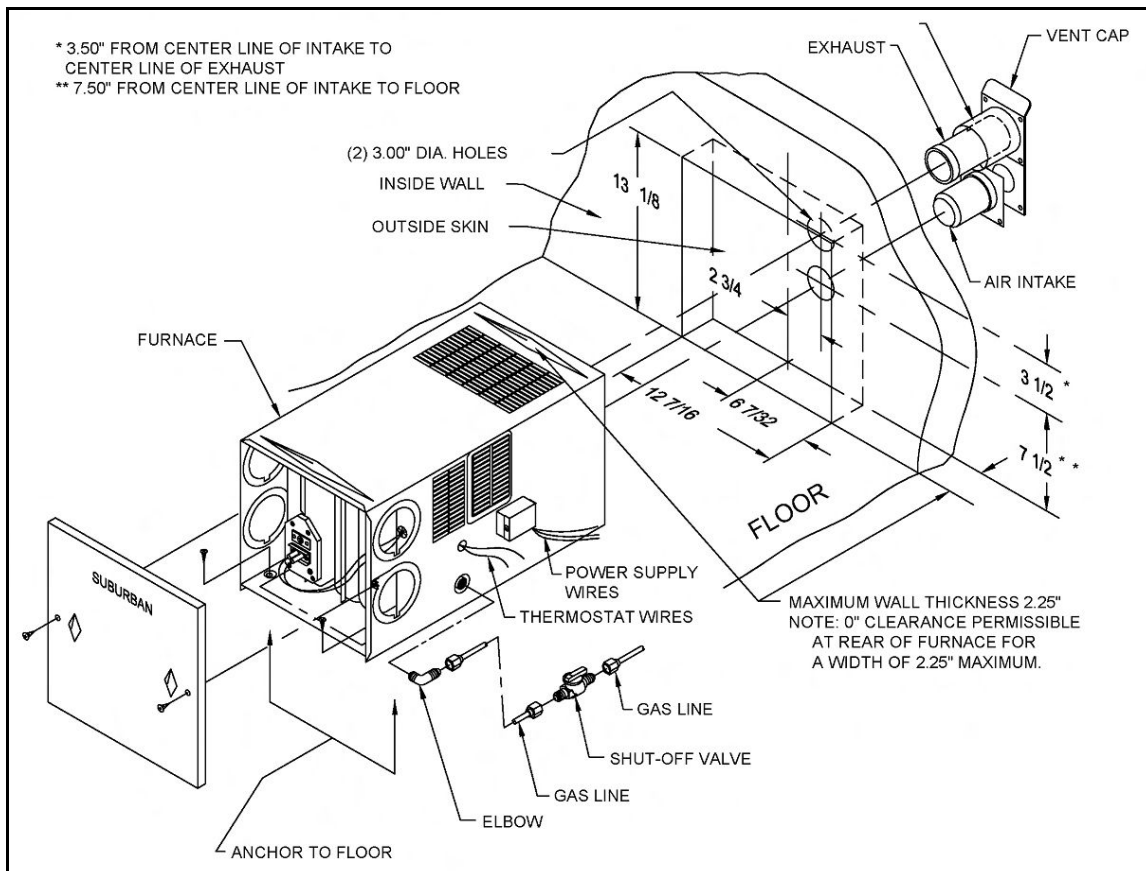

Figure 17
P-40

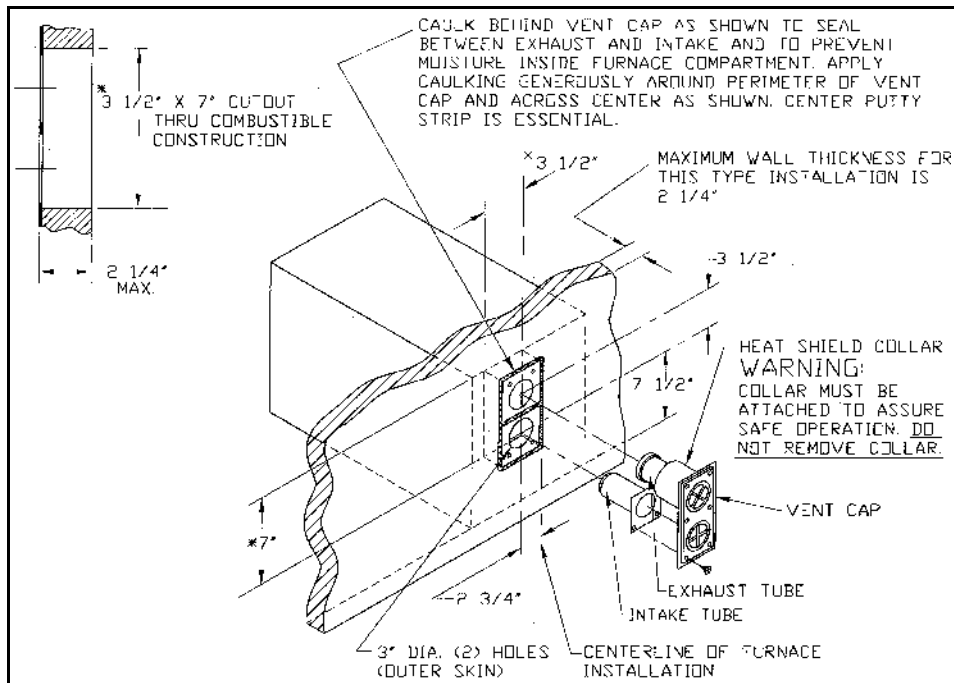

Figure 18
NT-40
P-40

RETURN AIR

Return Air - The cabinet that the furnace may be installed in will have louvers or openings for the return air back to the furnace. When the furnace is installed, it is imperative that the return air louvers on the furnace cabinet opening are not obstructed.

Usually, these furnaces are installed under a counter, sofa or bed in order to be out of the way. A grille or opening must be built into the cabinetry or into the base area of the sofa or bed. Return air from the living area of the trailer is drawn in through the grille and into the return air openings in the furnace cabinet. Figure 19 illustrates the return air circulation of the furnace. **Note: Refer to the installation manual for the minimum return air area for your specific furnace model.**

Insufficient return air will cause the furnace to overheat and cycle on limit. Another symptom of a return air problem is:

1. Furnace seems to run continuously in an effort to satisfy the thermostat.

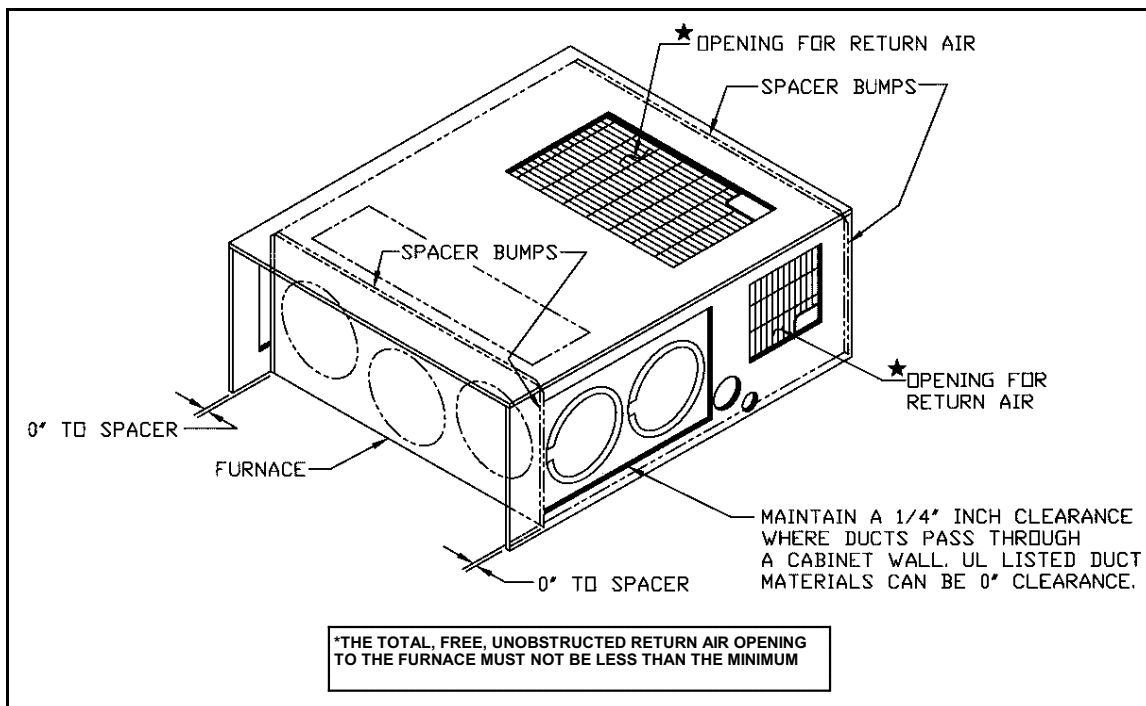

Figure 19

DUCTING

Ducting - Suburban furnaces require that a minimum duct area be maintained throughout entire duct system including through the register. It is very important to adhere to the minimum duct area in order to keep the furnace from cycling on high limit and to assure proper operation of the sail switch (sometimes referred to as a microswitch.) **NOTE: (Refer to the installation manual for the minimum ducted square inches area for each model.)**

NOTE: Ducts terminating in a dead air space (like holding tank compartments or cargo areas (Toy Boxes) with no means for return air recirculation should not be counted in the required duct area. Also, ducts 2" in diameter or smaller should not be counted in the required duct area.

When installing a duct system, avoid making a lot of turns. The straighter the duct system, the less the resistance to air flow and the better the performance of the furnace.

Avoid making sharp turns in the duct system. Sharp turns will increase the static pressure in the plenum area of the furnace and could cause the furnace to cycle on limit.

The duct connections to the furnace cabinet should be tight to eliminate any heat loss which could result in overheating of the component parts on the furnace as well as a reduction in the heated air flow through the ductwork.

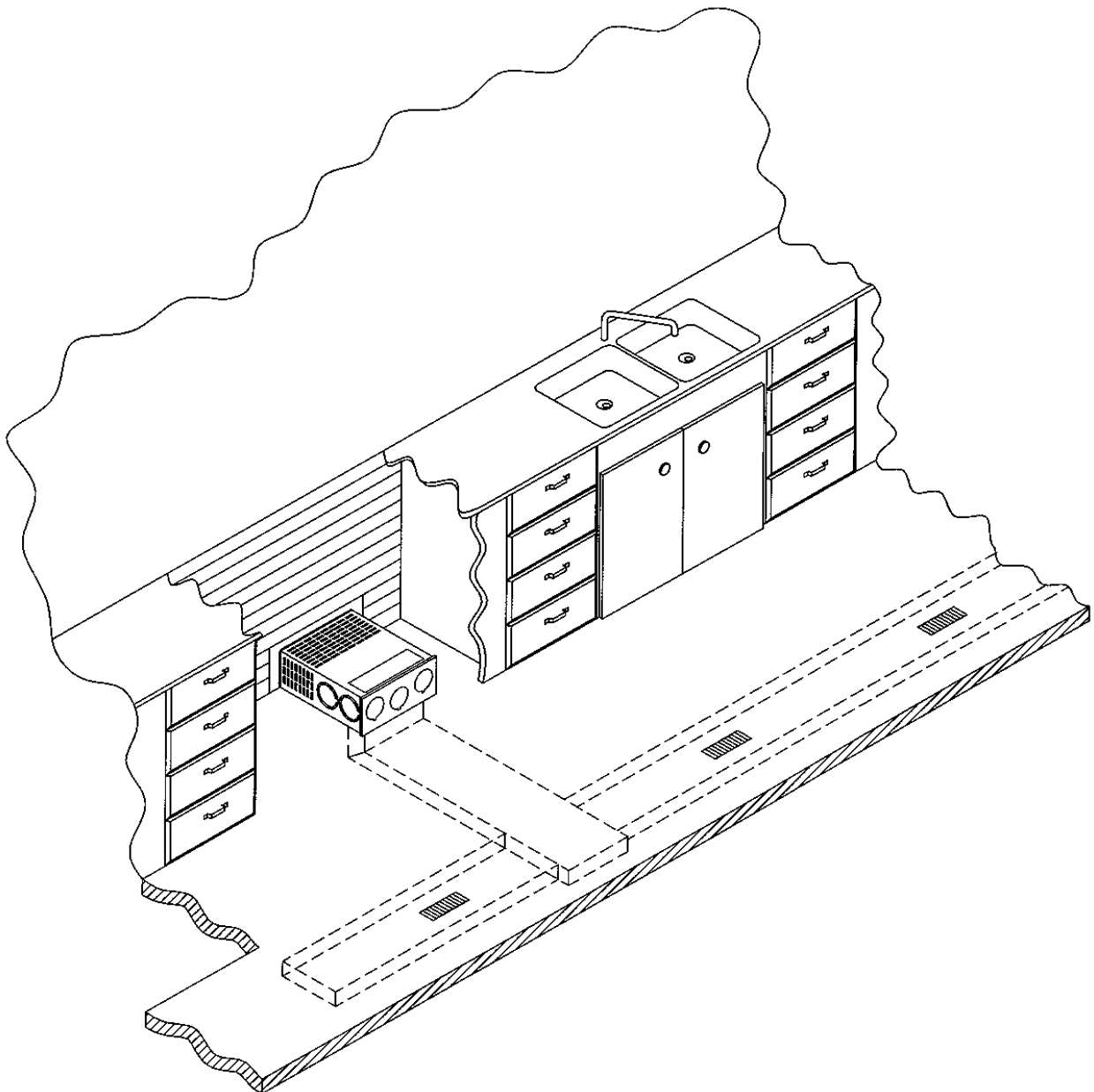

Figure 20

INSTALLATION REQUIREMENTS

Models	Clr Front	Clr Top	Clr Btm	Clr Back	Clr Left	Clr Right	Ducts Req'd	Btm Duct Sq Inch	Top Duct Sq Inch	L & R Side Duct Sq Inch	Return Air Sq inch
DD-17DSI	See *1	0"	0"	0"	0"	0"	n/a	n/a	n/a	n/a	n/a
NT-12S	3/8"	1"	0"	0"	1"	1"	2-4"	n/a	n/a	25"	55"
NT-16S	3/8"	1"	0"	0"	1"	1"	2-4"	n/a	n/a	25"	55"
NT-20S	1"	1"	0"	0"	1"	1"	2-4"	n/a	n/a	25"	55"
NT-12SE	See *1	5/8"	0"	0"	5/8"	5/8"	n/a	n/a	n/a	n/a	n/a
NT-16SE	See *1	5/8"	0"	0"	5/8"	5/8"	n/a	n/a	n/a	n/a	n/a
NT-20SE	See *1	5/8"	0"	0"	5/8"	5/8"	n/a	n/a	n/a	n/a	n/a
NT-24SP	0"	0"	0"	0"	1"	1"	3-4"	48"	n/a	36"	55"
NT-30SP	0"	0"	0"	0"	1"	1"	3-4"	48"	n/a	36"	55"
NT-34SP	0"	0"	0"	0"	2"	2"	4-4"	48"	n/a	48"	55"
NT-40	1"	1"	0"	0"	2"	2"	4-4"	48"	n/a	48"	113"
P-30	0"	0"	0"	0"	1"	1"	4-4"	48"	n/a	48"	55"
P-40	1"	1"	0"	0"	2"	2"	4-4"	48"	n/a	48"	113"

*1 - Special clearances for discharge grills. Refer to Installation and Instruction Manual.

*2 - Return air should be 142" if 4 ducts are used. May be reduced to 88" if 5 ducts are used.

NOTE: 0" clearance is to spacer (flanges)

INSTALLATION REQUIREMENTS

Models	Clr Front	Clr Top	Clr Btm	Clr Back	Clr Left	Clr Right	Ducts Req'd	Btm Duct Sq Inch	Top Duct Sq Inch	L & R Side Duct Sq Inch	Return Air Sq inch
SF-20/20F	1"	0"	0"	0"	0"	0"	2-4"	56"	56"	25"	55"
SF-25/25F	1"	0"	0"	0"	0"	0"	3-4"	56"	56"	36"	55"
SF-30/30F	1"	0"	0"	0"	0"	0"	3-4"	56"	56"	36"	55"
SF-35/35F	1"	0"	0"	0"	0"	0"	4-4"	56"	56"	48"	55"
SF-42/42F	1"	1"	0"	0"	2"	2"	4-4"	72" SEE *3	56"	48"	SEE *2
SH-35	1"	0"	0"	0"	1"	1"	4-4"	56"	56"	48"	55"
SH-42	1"	1"	0"	0"	2"	2"	4-4"	72" SEE *3	56"	48"	See *2
SHD-2542	1"	1"	0"	0"	2"	2"	4-4"	72" SEE *3	56"	48"	SEE *2

NOTE: 0" clearance is to spacer (flanges)

*1 - Special clearances for discharge grills. Refer to Installation and Instruction Manual.

*2 - Return air should be 142" if 4 ducts are used. May be reduced to 88" if 5 ducts used.

*3- Bottom duct required. SF42 uses kit # 520753, SH-42 and SHD-2542 uses kit #520864.

INSTALLATION REQUIREMENTS

Models	Clr Front	Clr Top	Clr Btm	Clr Back	Clr Left	Clr Right	Ducts Req'd	Btm Duct Sq Inch	Top Duct Sq Inch	L & R Side Duct Sq Inch	Return Air Sq inch
SFV-20/20F	1"	1"	0"	0"	1"	1"	SEE *4	52"	SEE *4	SEE *4	55"
SFV-25/25F	1"	1"	0"	0"	1"	1"	SEE *4	52"	SEE *4	SEE *4	55"
SFV-30/30F	1"	1"	0"	0"	1"	1"	SEE *4	52"	SEE *4	SEE *4	55"
SFV-35/35F	1"	1"	0"	0"	1"	1"	SEE *4	52"	SEE *4	SEE *4	55"
SFV-42/42F	1"	2"	0"	0"	1"	1"	SEE *4	52"	SEE *4	SEE *4	142"

NOTE: 0" clearance is to spacer (flanges)

*1 - Special clearances for discharge grills. Refer to Installation and Instruction Manual.

*2 - Return air should be 142" if 4 ducts are used. May be reduced to 88" if 5 ducts used.

*3 - Bottom duct required. SF42 uses kit # 520753, SH-42 and SHD-2542 uses kit #520864.

*4 - Vertical mount furnace review table below for ducting requirements. The duct requirements must be followed in order to assure proper operation of the furnace. The minimum open duct areas listed below must be maintained through the entire duct system including through register.

MODEL	TOP AND FRONT DUCTS (4" Round)	BOTTOM	LEFT DUCT	RIGHT DUCT
	Minimum Duct Area	Minimum Duct Area	Minimum Duct Area	
SFV-20(F)	*Optional Required 52 SQ. IN.	Required 52 SQ. IN.	*Optional	*Optional
SFV-25(F)	*Optional	Required 52 SQ. IN.	*Optional	*Optional
SFV-30(F)	*Optional	Required 52 SQ. IN.	*Optional	*Optional
SFV-35(F)	48 SQ. IN. (Bottom Front Duct Not To be Used)	52 SQ. IN.	56 SQ. IN.	
SFV-42(F)	48 SQ. IN. (Top Front Duct Not To Be Used.)	52 SQ. IN.	56 SQ. IN.	72 SQ. IN.

*Use of these ducts are in addition to the required use of the bottom duct.

FURNACE SPECIFICATIONS

12 VDC Model	Description	Input BTU/hr	Type Gas	Voltage	Motor Diameter	Amp Draw	Static Pressure	C.F.M. Max.
DD-17DSI	Direct Discharge	17,000	PROPANE	12 VDC	3"	2.9	n/a	145
NT-12S NT-12SE	Ducted Direct Discharge	12,000	PROPANE	12 VDC	3"	2.8	S - .1" wc SE - n/a	S - 122 SE -140
NT-16S NT-16SE	Ducted Direct Discharge	16,000	PROPANE	12 VDC	3"	2.8	S - .1" wc SE - n/a	S - 165 SE-140
NT-20S NT-20SE	Ducted Direct Discharge	19,000	PROPANE	12 VDC	3"	2.8	S - .1" wc SE-n/a	S - 165 SE-150
NT-24SP	Ducted	24,000	PROPANE	12 VDC	2.5"	3.5	.2" wc	265
NT-30SP	Ducted	30,000	PROPANE	12 VDC	2.5"	5.5	.2" wc	345
NT-34SP	Ducted	34,000	PROPANE	12 VDC	2.5"	7.5	.1" wc	373
NT-40	Ducted	40,000	PROPANE	12 VDC	2.5"	9.5	.155"/.20B	441
Park Models P-30S	Ducted	30,000	PROPANE	120 VAC	3"	2.5	.15" wc	345
P-40**	Ducted	40,000	PROPANE	120 VAC	3"	2.0	.15" wc	441

NOTES

**P-40 Park Model Furnace and valve is convertible to Natural Gas. Instructions on converting unit to Natural Gas are on sticker on side of cabinet.

FURNACE SPECIFICATIONS

12 VDC Model	Description	Input BTU/hr	Type Gas	Voltage	Motor Diameter	Amp Draw	Static Pressure	C.F.M. Max.
SF-20/20F	Ducted	20,000	PROPANE	12 VDC	3"	6.5=2.5 in. Motor 8.5=3 in. Motor	.2" wc	300
SF-25/25F	Ducted	25,000	PROPANE	12 VDC	3"	6.5=2.5 in. Motor 8.5=3 in. Motor	.2" wc	300
SF-30/30F	Ducted	30,000	PROPANE	12 VDC	3"	6.5=2.5 in. Motor 8.5=3 in. Motor	.2" wc	300
SF-35/35F	Ducted	35,000	PROPANE	12 VDC	3"	8.5=2.5 in. Motor 9.4=3 in. Motor	.2" wc	375
SF-42/42F	Ducted	40,000	PROPANE	12 VDC	3"	11.5	.25" wc	430
SFV-20/20F	Ducted	20,000	PROPANE	12 VDC	3"	8.5	.2" wc	300
SFV-25/25F	Ducted	25,000	PROPANE	12 VDC	3"	8.5	.2" wc	300
SFV-30/30F	Ducted	30,000	PROPANE	12 VDC	3"	8.5	.2" wc	300
SFV-35/35F	Ducted	35,000	PROPANE	12 VDC	3"	9.4	.2" wc	375
SFV-42/42F	Ducted	40,000	PROPANE	12 VDC	3"	11.5	.25" wc	430
SH-35/35F	Ducted	35,000	PROPANE	12 VDC	3"	8.2	.2" wc	375
SH-42/42F	Ducted	40,000	PROPANE	12 VDC	3"	10.6	.25" wc	430
SHD-2542	Ducted	25,000 42,000	PROPANE	12 VDC	3"	8.8 (Low) 12 (High)	.25" wc	430

SEQUENCE OF OPERATION For Furnaces Equipped With Time Delay

The thermostat controls the operating circuit to the furnace by reacting to room temperature to open and close a set of contact points which allows current to flow to the ON and OFF switch then to the relay.

The relay receives the power and allows power to pass through to the switch within the relay. This is done by a heater coil within the relay which actuates a bi-metal disc closing the relay circuit.

The power then flows to the motor and allows the blower to operate. One end of the motor shaft drives the room air wheel. The other end of the motor shaft drives the combustion air wheel that delivers the required air to the burner for combustion.

The limit switch is an in-line device which protects the furnace from over heating conditions. The contacts in the limit switch open at a given temperature setting, shutting off power to the ignition system which controls the gas valve.

As the room air wheel comes up to speed, air flow closes the sail switch completing the circuit. The sail switch is placed into the system as a safety to prove there is adequate air for combustion.

The next operation is controlled by the Direct Spark Ignition, (DSI) system as power is applied to the DSI board. The system will do the following.

1. The board has a timing circuit which allows the blower to purge the chamber of any products of combustion or gas.
2. The board will then apply power to the gas valve. At the same time it produces a high voltage power supply to the electrode producing spark at the burner.
3. The board will also confirm the presence of a flame. If the flame is not sensed after 7 seconds, the module will try two (2) more times and then go into lock-out. The flame is sensed through the spark wire and electrode.

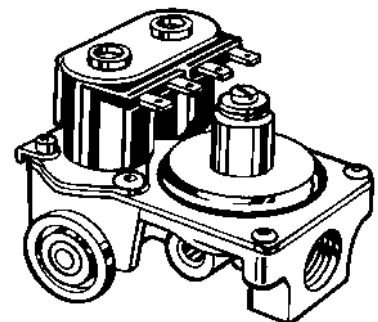
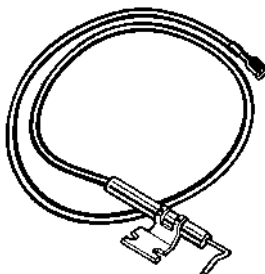
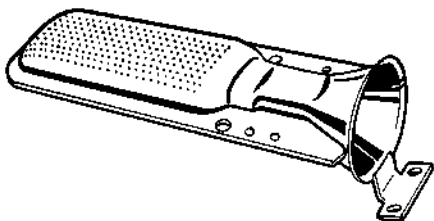
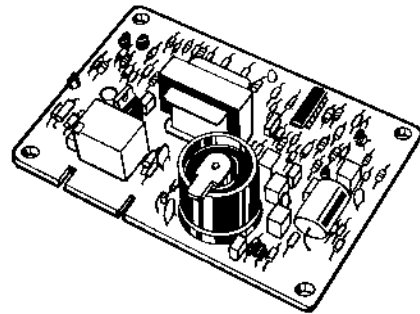
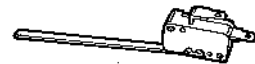
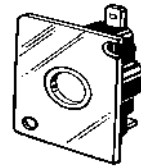
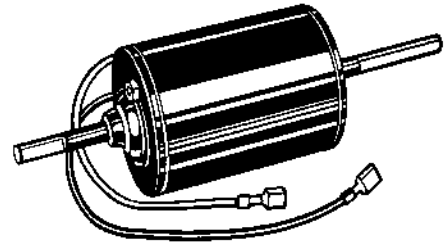
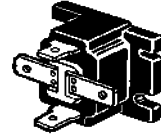

When the thermostat has reached the set point with the room air temperature, the contacts will open removing power from the controls. The blower will remain on until the relay opens and stops the motor.

NOTE: On some models, sail switch is before limit switch.



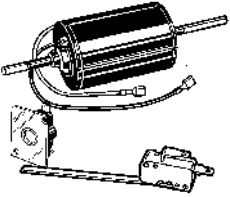
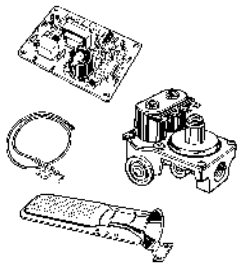

Sequence of Operation for Fan Control Module Board

Part Number 520820

Time Line	Description - Sequence of Events	
<p>Start</p> <p>Thermostat Calls for Heat</p>	<p>The wall thermostat controls the operation of the furnace by reacting to room temperature, this allows current to flow through the On/Off switch to the module board.</p> <p>The module board constantly checks for a minimum 9.5 volts. If there is not 9.5 volts, the module board will go into a stand by mode until adequate power is supplied. It will then resume normal operation.</p> <p>Upon a call from the thermostat, the module board thermostat circuit will go active. The sail switch circuit is verified as being open. The blower output is energized. Blower motor starts.</p>	
<p>15 Seconds Purge Cycle</p>	<p>The module board will then verify that the sail switch circuit is closed and motor is up to speed. If this circuit remains open for 30 seconds after the blower motor starts, the module board will go into lock out and shut down the blower motor.</p> <p>The module board checks that the gas valve relay contacts (which are located on the module board) are open before the ignition sequence starts.</p> <p>The board has a pre-purge timing circuit of (approximately 15 seconds). This allows the chamber to purge.</p>	
<p>7 Seconds Ignition Cycle and Flame Sense</p>	<p>The module board will energize the gas valve and enable the high voltage spark output to the electrode for 7 seconds of ignition time.</p> <p>The module board will then check for flame sense to verify successful lighting of the main burner flame. Sparking will then be terminated and the gas valve and blower outputs will remain energized.</p> <p>If ignition is successful the module board will monitor the flame sense, sail switch and limit switch circuits, and the thermostat inputs during the heating period.</p> <p>The flame is sensed through the spark wire and electrode. Therefore, it is essential that the electrode is properly positioned in the burner flame.</p>	
<p>2nd and 3rd Ignition Cycles if Required</p>	<p><u>3 Try Ignition Board</u></p> <p>If the flame is <u>not</u> sensed after seven (7) seconds, a second 15 second purge cycle will begin followed by a second Trial-For-Ignition sequence. After three (3) Trial-For-Ignition attempts with no ignition of the main burner, the module board will de-energize the gas valve immediately and blower will run for 3 minutes and then shutdown in lockout.</p>	
<p>Heating Cycle</p>	<p>If during the heating cycle, the limit switch circuit opens and remains open for 5 minutes, the module board will go into lock out and shut down the blower motor. If this occurs, the thermostat will need to be reset for the furnace to operate.</p>	
<p>90 Second Shut Down</p>	<p>When the thermostat has reached its set point and the demand for heat ends, the gas valve will be de-energized and the flame will go out. The post purge period of 90 seconds begins. When it times out, the blower motor output is removed, and the blower stops.</p>	

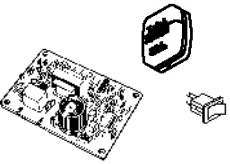
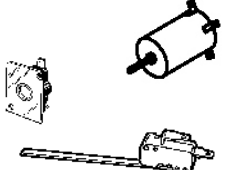
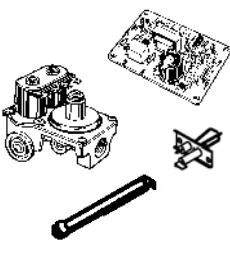
Sequence of Operation for 24 VAC Fan Control Module Board Part Number 520947

Time Line	Description - Sequence of Events	
<p>Start</p> <p>Thermostat Calls for Heat</p>	<p>The wall thermostat controls the operation of the furnace by reacting to room temperature, this allows current to flow through the On/Off switch to the module board.</p> <p>The module board must have a minimum 18 volts for normal operation.</p> <p>Upon a call from the thermostat, the module board thermostat circuit will go active. The sail switch circuit is verified as being open. The blower output is energized. Blower motor starts.</p>	
<p>15 Seconds Purge Cycle</p>	<p>The module board will then verify that the sail switch circuit is closed and motor is up to speed. If this circuit remains open blower motor will run continuously until sail switch closes.</p> <p>The module board checks that the gas valve relay contacts (which are located on the module board) are open before the ignition sequence starts.</p> <p>The board has a pre-purge timing circuit of (approximately 15 seconds). This allows the chamber to purge.</p>	
<p>7 Seconds Ignition Cycle and Flame Sense</p>	<p>The module board will energize the gas valve and enable the high voltage spark output to the electrode for 7 seconds of ignition time.</p> <p>The module board will then check for flame sense to verify successful lighting of the main burner flame. Sparking will then be terminated and the gas valve and blower outputs will remain energized.</p> <p>If ignition is successful the module board will monitor the flame sense, sail switch and limit switch circuits, and the thermostat inputs during the heating period.</p> <p>The flame is sensed through the flame sense electrode. Therefore, it is essential that the electrode is properly positioned in the burner flame.</p>	
<p>2nd and 3rd Ignition Cycles if Required</p>	<p><u>3 Try Ignition Board</u></p> <p>If the flame is <u>not</u> sensed after seven (7) seconds, a second 15 second purge cycle will begin followed by a second Trial-For-Ignition sequence. After three (3) Trial-For-Ignition attempts with no ignition of the main burner, the module board will de-energize the gas valve immediately and blower will run for 90 seconds and then shutdown in lockout.</p>	
<p>Heating Cycle</p>	<p>If during the heating cycle, the limit switch circuit opens and remains open the gas valve will close and the blower motor will continue to run.</p>	
<p>90 Second Shut Down</p>	<p>When the thermostat has reached its set point and the demand for heat ends, the gas valve will be de-energized and the flame will go out. The post purge period of 90 seconds begins. When it times out, the blower motor output is removed, and the blower stops.</p>	

Sequence of Operations for SHD-2542

1st Stage Call for Heat

The wall thermostat controls the operation of the dual stage furnace by reacting to room temperature. This allows current to flow through the On/Off switch to the Blower Speed Control Board then to the Module Board.

The module board constantly checks for a minimum 9.5 volts. If there is not 9.5 volts, the module board will go into a standby mode until adequate power is supplied. It will then resume normal operation.

Upon a call from the thermostat the first stage will be activated. The module board thermostat circuit will go active and the sail switch is verified as being open. The blower output is energized. The blower motor starts.

15 Second Purge Cycle

The module board will then verify that the sail switch circuit is closed and motor is up to speed. If this circuit remains open for 30 seconds after the blower motor starts, the module board will go into lockout and shut down the blower motor.

The module board checks that the gas valve relay contacts (located on the module board) are open before the igniting sequence starts.

The board has a pre-purge timing circuit of approximately 15 seconds. This allows the combustion chamber to purge.

7 Second Ignition Cycle and Flame Sense

The module board will energize the gas valve and enable the high voltage spark output to the electrode for a seven second ignition period.

The module board will then check for flame sense to verify successful lighting of the main burner flame. Sparking of the igniter is then terminated. The gas valve and blower outputs will remain energized.

If ignition is successful the module board will monitor the flame sense, sail switch, and the limit switch circuits. The flame is sensed through the spark wire and electrode therefore, it is essential that the electrode is properly positioned in the burner flame.

3 try Ignition Board

If the flame is NOT sensed after seven (7) seconds, or if the unit fails to ignite, a second fifteen (15) purge cycle will begin followed by second trial for ignition sequence. After three (3) trial for ignition attempts with no ignition of the main burner, the module board will de-energize the gas valve immediately and the blower will run for three (3) minutes and then go into lockout mode.

2nd Stage Heating

If during the thermostat cycle the demand for heat drops below the second stage thermostat setting (3 to 5 degrees variance depending on thermostat manufacturer), the blower speed control board will be energized. The blower speed control board will energize the additional gas valve solenoid and increase motor speed to the high position. Furnace will remain in the second stage operation until thermostat is satisfied.

90 Second Shut Down

When the thermostat has reached its set point and the demand for heat ends, the gas valve will be de-energized and the flame will go out. The post combustion purge period of 90 seconds begins. When it times out, the blower motor output is removed, and the blower stops.

TROUBLE SHOOTING GUIDE

SUBURBAN RV FURNACES with TIME DELAY

12 VDC HEATING SECTION

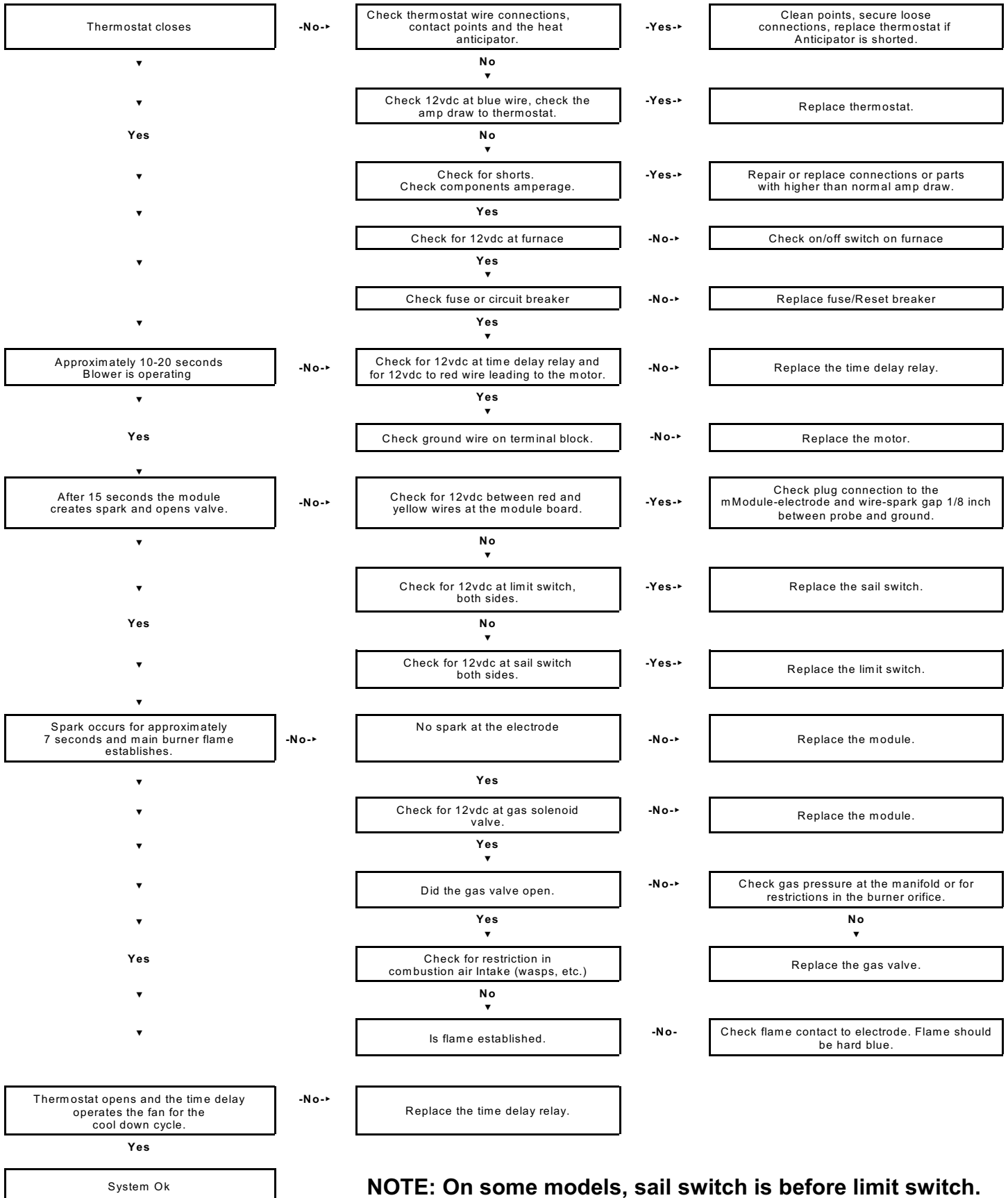

NOTE: On some models, sail switch is before limit switch.

TROUBLE SHOOTING GUIDE

SUBURBAN RV FURNACE with FAN CONTROL MODULE BOARDS

12 VDC HEATING SECTION

<div style="border: 1px solid black; padding: 5px; margin-bottom: 5px;">Thermostat Closes</div> <div style="text-align: center;">▼</div> <div style="text-align: center;">▼</div> <div style="text-align: center;">Yes</div> <div style="text-align: center;">▼</div> <div style="text-align: center;">▼</div> <div style="text-align: center;">▼</div> <div style="text-align: center;">▼</div> <div style="text-align: center;">▼</div>	-No->	<div style="border: 1px solid black; padding: 5px; margin-bottom: 5px;">Check thermostat wire connections, contact points and the heat anticipator.</div> <div style="text-align: center;">No</div> <div style="text-align: center;">▼</div> <div style="border: 1px solid black; padding: 5px; margin-bottom: 5px;">Check 12vdc at blue wire, check the amp draw to thermostat.</div> <div style="text-align: center;">No</div> <div style="text-align: center;">▼</div> <div style="border: 1px solid black; padding: 5px; margin-bottom: 5px;">Check for shorts. Check components amperage.</div> <div style="text-align: center;">Yes</div> <div style="border: 1px solid black; padding: 5px; margin-bottom: 5px;">Check for 12vdc at furnace</div> <div style="text-align: center;">Yes</div> <div style="text-align: center;">▼</div> <div style="border: 1px solid black; padding: 5px; margin-bottom: 5px;">Check fuse or circuit breaker</div> <div style="text-align: center;">Yes</div> <div style="text-align: center;">▼</div>	-Yes->	<div style="border: 1px solid black; padding: 5px; margin-bottom: 5px;">Clean points, secure loose connections, replace thermostat if anticipator is shorted.</div> <div style="border: 1px solid black; padding: 5px; margin-bottom: 5px;">Replace thermostat.</div> <div style="border: 1px solid black; padding: 5px; margin-bottom: 5px;">Repair or replace connections or parts with higher than normal amp draw.</div> <div style="border: 1px solid black; padding: 5px; margin-bottom: 5px;">Check on/off switch on furnace</div> <div style="border: 1px solid black; padding: 5px; margin-bottom: 5px;">Replace fuse/Reset breaker.</div>
<div style="border: 1px solid black; padding: 5px; margin-bottom: 5px;">Blower is operating at call for heat.</div> <div style="text-align: center;">▼</div> <div style="text-align: center;">Yes</div>	-No->	<div style="border: 1px solid black; padding: 5px; margin-bottom: 5px;">Check for 12vdc at power terminal on module board and for 12vdc to red wire leading to the motor.</div> <div style="text-align: center;">Yes</div> <div style="text-align: center;">▼</div> <div style="border: 1px solid black; padding: 5px; margin-bottom: 5px;">Check ground wire on terminal block.</div>	-No->	<div style="border: 1px solid black; padding: 5px; margin-bottom: 5px;">Replace the module board after confirming motor operation.</div> <div style="border: 1px solid black; padding: 5px; margin-bottom: 5px;">Replace the motor.</div>
<div style="border: 1px solid black; padding: 5px; margin-bottom: 5px;">Motor is operating</div> <div style="text-align: center;">▼</div> <div style="text-align: center;">Yes</div>	-No->	<div style="border: 1px solid black; padding: 5px; margin-bottom: 5px;">Reset thermostat. Motor operating. Check for 12 vdc at blue wire on molex edge connector.</div>	-Yes->	<div style="border: 1px solid black; padding: 5px; margin-bottom: 5px;">Verify voltage thru limit and sail switch to module board. If circuit remains open for 30 seconds, module board will go into lockout and shut down motor. Reset thermostat. Replace defective part.</div>
<div style="border: 1px solid black; padding: 5px; margin-bottom: 5px;">After 15 seconds the module creates spark and opens valve.</div> <div style="text-align: center;">▼</div> <div style="text-align: center;">▼</div> <div style="text-align: center;">Yes</div> <div style="text-align: center;">▼</div> <div style="text-align: center;">▼</div>	-No->	<div style="border: 1px solid black; padding: 5px; margin-bottom: 5px;">Check for 12vdc between red and yellow wires at the module board.</div> <div style="text-align: center;">No</div> <div style="text-align: center;">▼</div> <div style="border: 1px solid black; padding: 5px; margin-bottom: 5px;">Check for 12vdc at limit switch, both sides.</div> <div style="text-align: center;">No</div> <div style="text-align: center;">▼</div> <div style="border: 1px solid black; padding: 5px; margin-bottom: 5px;">Check for 12vdc at sail switch both sides.</div>	-Yes->	<div style="border: 1px solid black; padding: 5px; margin-bottom: 5px;">Check plug connection to the module-electrode and wire-spark gap 1/8 inch between probe and ground.</div> <div style="border: 1px solid black; padding: 5px; margin-bottom: 5px;">Replace the sail switch.</div> <div style="border: 1px solid black; padding: 5px; margin-bottom: 5px;">Replace the limit switch.</div>
<div style="border: 1px solid black; padding: 5px; margin-bottom: 5px;">Spark occurs for approximately 7 seconds and main burner flame establishes.</div> <div style="text-align: center;">▼</div> <div style="text-align: center;">▼</div> <div style="text-align: center;">▼</div> <div style="text-align: center;">▼</div> <div style="text-align: center;">▼</div> <div style="text-align: center;">Yes</div> <div style="text-align: center;">▼</div> <div style="text-align: center;">▼</div>	-No->	<div style="border: 1px solid black; padding: 5px; margin-bottom: 5px;">No spark at the electrode</div> <div style="text-align: center;">Yes</div> <div style="border: 1px solid black; padding: 5px; margin-bottom: 5px;">Check for 12vdc at gas solenoid valve.</div> <div style="text-align: center;">Yes</div> <div style="text-align: center;">▼</div> <div style="border: 1px solid black; padding: 5px; margin-bottom: 5px;">Did the gas valve open.</div> <div style="text-align: center;">Yes</div> <div style="border: 1px solid black; padding: 5px; margin-bottom: 5px;">Check for restriction in combustion air Intake (wasps, etc.)</div> <div style="text-align: center;">No</div> <div style="text-align: center;">▼</div> <div style="border: 1px solid black; padding: 5px; margin-bottom: 5px;">Is flame established.</div>	-No->	<div style="border: 1px solid black; padding: 5px; margin-bottom: 5px;">Replace the module.</div> <div style="border: 1px solid black; padding: 5px; margin-bottom: 5px;">Replace the module.</div> <div style="border: 1px solid black; padding: 5px; margin-bottom: 5px;">Check gas pressure at the manifold or for restrictions in the burner orifice.</div> <div style="text-align: center;">No</div> <div style="text-align: center;">▼</div> <div style="border: 1px solid black; padding: 5px; margin-bottom: 5px;">Replace the gas valve.</div> <div style="border: 1px solid black; padding: 5px; margin-bottom: 5px;">Check flame contact to electrode. Flame should be hard blue.</div>
<div style="border: 1px solid black; padding: 5px; margin-bottom: 5px;">Thermostat opens and the module board operates the fan for the cool down cycle.</div> <div style="text-align: center;">▼</div> <div style="text-align: center;">Yes</div>	-No->	<div style="border: 1px solid black; padding: 5px; margin-bottom: 5px;">Replace the module board</div>		
<div style="border: 1px solid black; padding: 5px; margin-bottom: 5px;">System Ok</div>				

SERVICE HINTS, DIAGNOSIS, AND CORRECTIVE MEASURES

FOR THE IGNITION SYSTEMS OF SUBURBAN 24 VOLT ELECTRONIC IGNITION GAS FURNACES WITH TIME DELAY

CAUTIONS:

1. Never operate the furnace with the electrode wire disconnected nor with the electrode assembly removed from the furnace.
2. Never use a screwdriver on any part of the electrode assembly while the furnace is in operation.
3. Be certain that the spark from the electrode never reaches the flame sensor portion of the electrode assembly.

4. Be sure the electrode assembly screws are snug at all times, especially after the electrode has been removed and reinstalled.
5. If the module board is found to be defective, it must be replaced - it is not field repairable. Any attempts to repair the board may alter the board and cause it to operate in an unsatisfactory manner.
6. Insure that the gap between electrode and ground is always 1/8". The gap between the flame sensor should be approximately twice the gap between electrode and ground to insure no sparking to sensor. Sparking to sensor will damage the module board.

The electronic ignition system is made up of three main parts; the module board, the electrode assembly, and the electrode wire. The module board is the brain of the electronic ignition system and it has several functions.

1. When the blower reaches approximately 75% of the normal r.p.m. and sufficient air flow is established, the sail switch engages and completes a 24 volt circuit through the limit switch to the module board.
2. After a 12 - 18 second delay, 24 volt current will pass through the module board to the solenoid valve. The current to the valve opens it and allows gas to the main burner; simultaneously, the module board sends high voltage through the electrode wire to the electrode assembly. The voltage seeks a ground between electrode and ground probe and a spark occurs. The spark then ignites the main burner.

3. The module board also performs the lockout function in cases where the spark fails to light the burner. When lockout occurs, the spark stops, the voltage from the module board to the gas valve is discontinued, and the valve closes. The unit will remain in lockout and the blower will continue to run until the thermostat is turned off. Turning the thermostat off disengages the lockout function of the module board. After the blower has stopped, the ignition sequence can be started again. The module will try three times for ignition before lockout.

It is important to determine the type problem being experienced, then the proper checkout procedure can be made. The following is a list of problems, how to identify in which area the problem is located, and how to correct it.

1. Electrode not sparking - with blower running and micro switch engaged, check the following:

- a. Check for proper voltage at module board after the blower motor reaches full r.p.m. If no voltage, check continuity through micro switch and limit switch. Also check wiring and wire connections.
- b. Voltage is present but no spark at electrode after 12 - 18 second delay, check electrode wire connections.
- c. Wire connections OK, but electrode wire does not show continuity through it - replace electrode wire.
- d. Electrode wire does show continuity through it - check electrode gap to be sure it is 1/8" maximum between electrode and ground. NOTE: Gap between sensor and ground must be twice electrode gap.
- e. Electrode gap OK - check electrode assembly for possible cracks or carbon on tip of electrode.
- f. Electrode OK - replace module board.

2. Electrode sparking, but gas not coming through burner:

- a. Check to see if voltage is coming out of module board to gas valve after the 12 - 18 second delay. Check the wires in the moxex connector to be sure they are intact and making contact with the module board. Check wire from the module board to valve for continuity. Wire and connections check OK - replace module board.
- b. Voltage is coming out of module board to gas valve, but gas valve does not open - replace gas valve.

3. Electrode sparking and gas valve opening, but burner will not light:

- a. Check to see if gas is coming through to the burner. This can be accomplished by using a flow meter in the gas supply line. If no gas is coming through the burner, check for obstruction in gas line, in main burner orifice, or in main burner.
- b. Gas is coming through burner, but spark will still not ignite burner - check gas pressure.

Line Pressure - Min. 11" W.C.*, Max. 14" W.C.

To properly check pressure, first determine the line pressure, cycle furnace and check pressure drop on demand. The drop in pressure should not be more than 1/2" W.C. A drop of more than 1/2" would indicate a faulty regulator, a restriction in the gas line, or a pinched gas line. Excessive pressure drop could also be due to moisture contamination.

- c. Gas pressure OK - check for obstruction in main burner; check to be sure electrode is positioned approximately 1/4" above and directly over slots on the main burner - adjust electrode if necessary.

- d. Remove burner and check burner for obstructions. Clean as required.

4. Burner ignites, but goes off and into lockout:

- a. Check to be certain that flame sensor is over slots in the main burner and that the main burner flame is burning against the tip of the flame sensor - adjust by bending sensor probe. NOTE: Sensor probe should be in the inner blue cone of the burner flame (approximately 1/4" to 5/16" above burner).
- b. Burner still goes off and into lockout - check wire connections at flame sensor and at module board.
- c. Wire connections OK - check continuity through flame sensor wire.
- d. Continuity of flame sensor wire OK - check with micro amp meter in series with flame sensor and flame sensor wire to be certain that the flame sensor is generating at least seven micro amps within seven seconds after the burner is ignited. Connect meter as follows: (+) to sensor wire, (-) to sensor probe. Adjust position of sensor probe, check for carbon deposits on sensor probe if reading is less than seven micro amps.
- e. Flame sensor circuit generating at least seven micro amps, but burner still goes off and into lockout - replace module board.

5. Repeated module board failures:

- a. Check to be certain that the electrode spark is not sparking against the flame sensor portion of the electrode assembly.
- b. Check to be sure module board or high voltage wires are not shorted to the chamber wrapper or other furnace parts.
- c. Be sure insulator covering the electrode wire connection on the coil of the module board is in place and insulator behind module board is in place.
- d. Make certain that the transformer voltage is within 24 - 30 volts A.C.
- e. Be sure duct connections to furnace are airtight. Seal duct collar connections to furnace cabinet with duct tape, if necessary to prevent hot air leakage. No air leakage should exist anywhere in the duct system, especially at connections on furnace cabinet.
- f. Be sure sensor wire terminal is tightly affixed to sensor probe.
- g. Be sure high voltage electrode wire is in good condition and properly positioned onto pierce point electrode.

6. Customer complains of unit going into lockout only once in a while:

- a. Thoroughly check electrode and burner relationship.
- b. Lockout can occur if the gas pressure fluctuates at the time the thermostat calls for heat. Pressure fluctuations can be caused by a malfunctioning gas bottle regulator, an obstruction or a kink in the gas line, or moisture in the gas bottle regulator or in the gas lines. It is difficult to check for these fluctuations that will not noticeably affect any other appliance in the coach. However, isolating the furnace from the coach gas system will determine if the gas system is responsible. This isolation procedure can be done by connecting a separate upright bottle, regulator and gas line directly to the furnace, eliminating the coach gas system. If the occasional lockout still exists, then the furnace should be thoroughly tested to determine the cause; however, if the furnace works properly on this separate system, then the coach gas system should be checked.
- c. Check furnace return air and warm air discharge to be certain sufficient air flow is present to engage micro switch every time.
- d. Check micro switch to be sure it moves freely.
- e. Remove electrode and burner. Clean thoroughly.

- f. When moisture in the gas system is suspected as being the problem, especially where the horizontal type gas bottle is being used, the following steps should be taken to prepare the gas system against further moisture problems:
Corrective Measures:
 1. Disconnect gas bottle and drain it completely dry of all gas and all moisture.
 2. Disconnect and blow out all gas lines completely dry.
 3. Check pressure regulator on the gas bottle. Replace if necessary.
 4. Add the drying agent. One half pint of methanol alcohol per 100 pound bottle capacity is recommended.
 Precautions:
 5. Never fill the gas bottle over 80%.
 6. Do not use the gas bottle completely dry to avoid using up the drying agent.

We have found the above procedures to be effective in solving most occasional lockout problems, especially where the horizontal type gas bottle is used. All of these steps must be performed as described for the preparation of a contaminated gas system to be 100% effective.

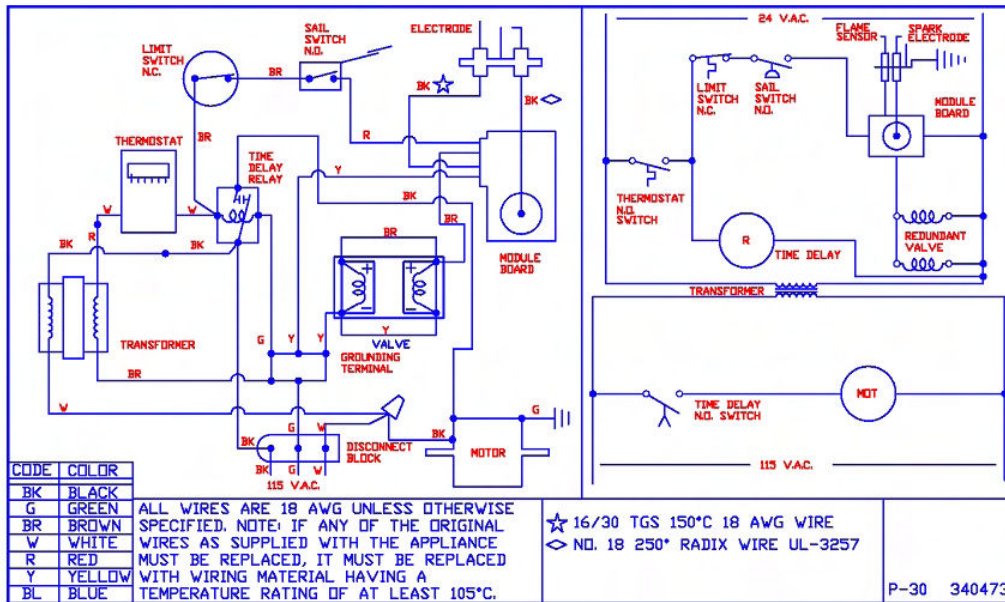

Figure 21
P-30S with Time Delay

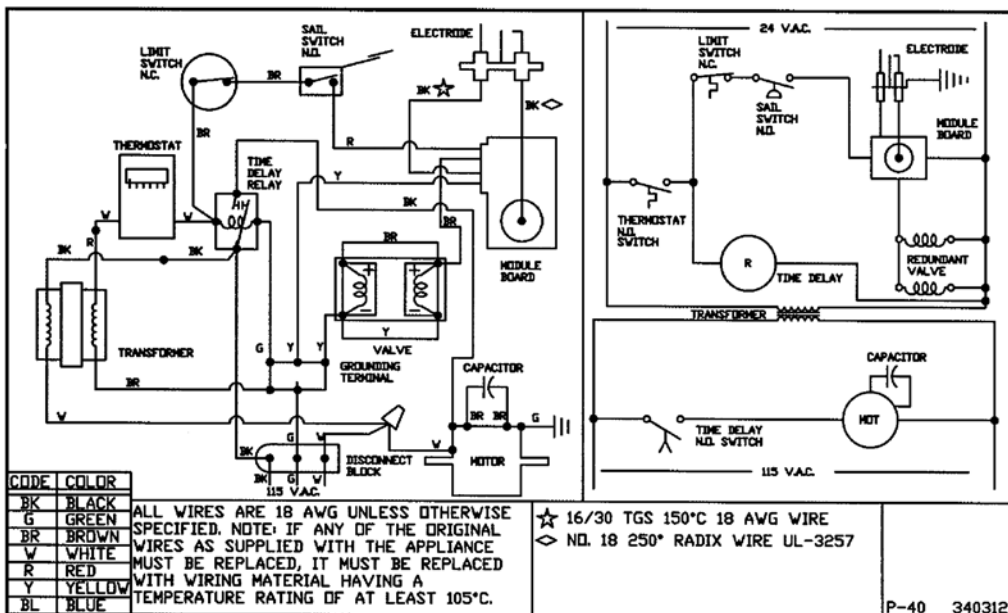

Figure 22
P-40 with Time Delay

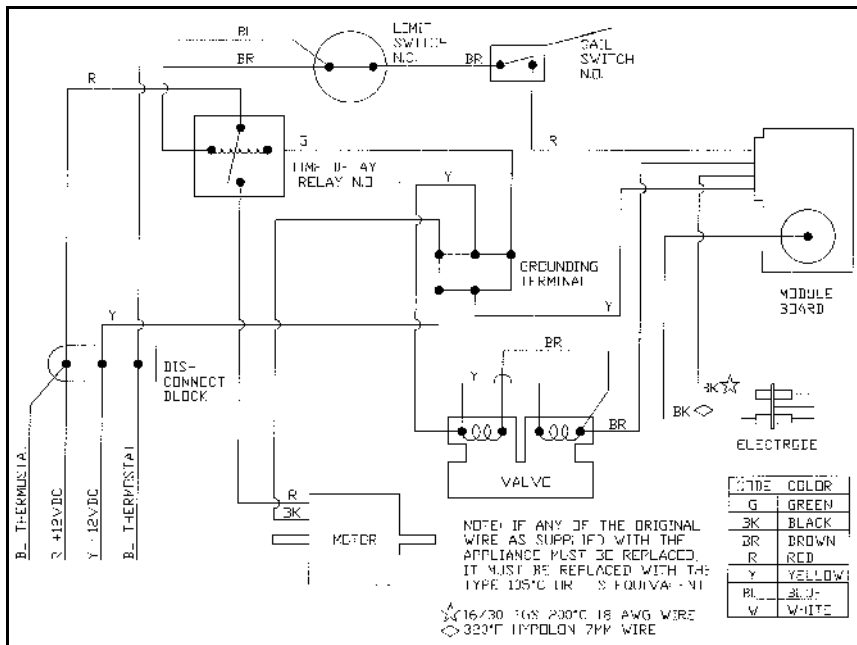

Figure 23
Remote Flame Sense
With Time Delay

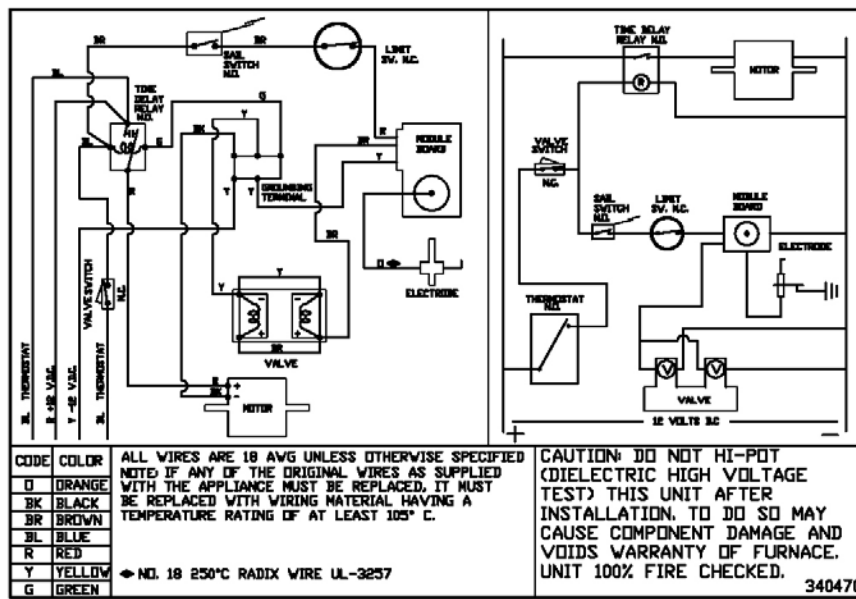

Figure 24
Remote Flame Sense
(NT Models)
With Time Delay

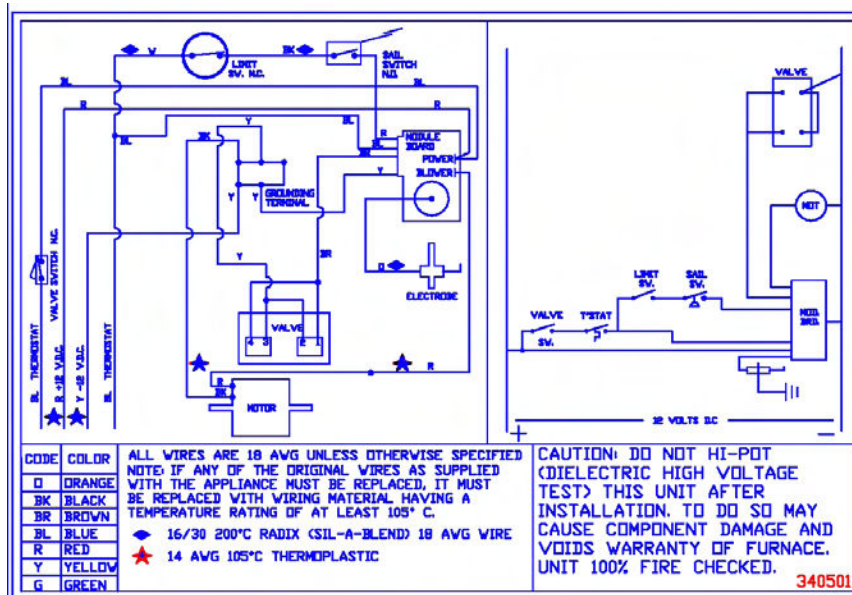

Figure 25
Remote Control Board
(SF-20/25/30/35/42F)

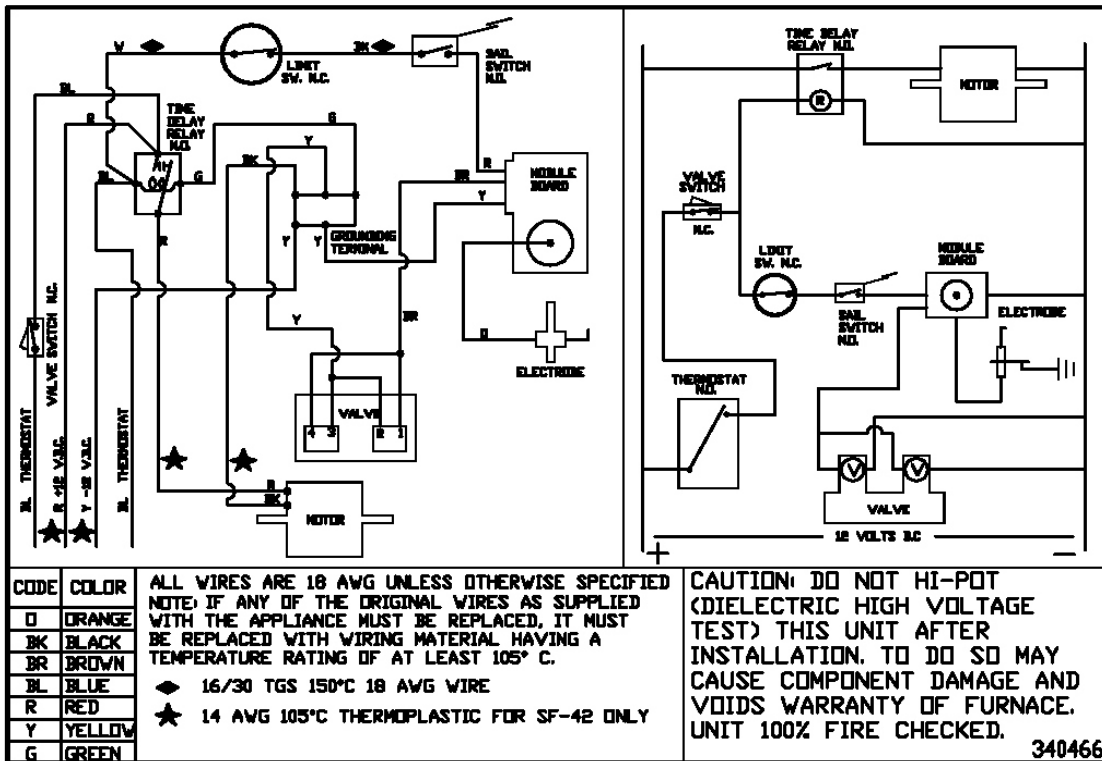

Figure 26
 Local Flame Sense
 (SF Models)
 With Time Delay

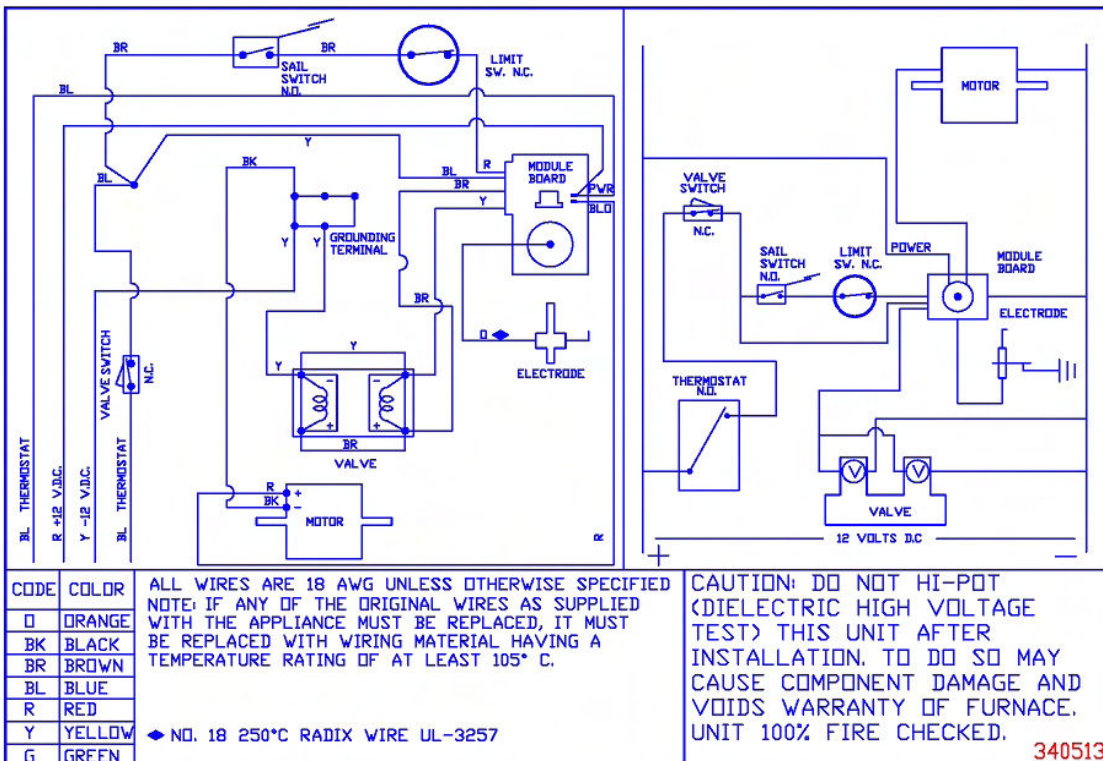

Figure 27
 Fan Control Board
 (NT-12/16/20S and SE)

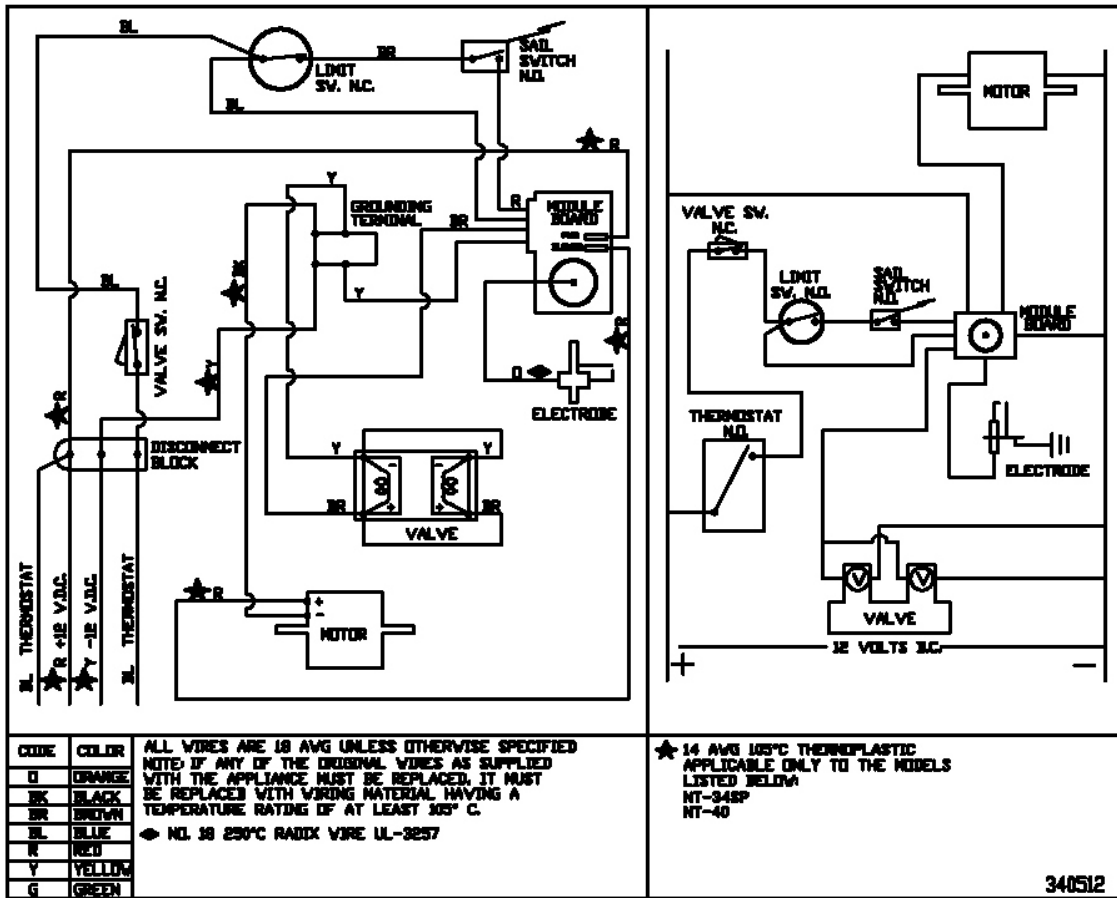

Figure 28
 Fan Control Board
 (NT-24/30/34SP and NT-40)

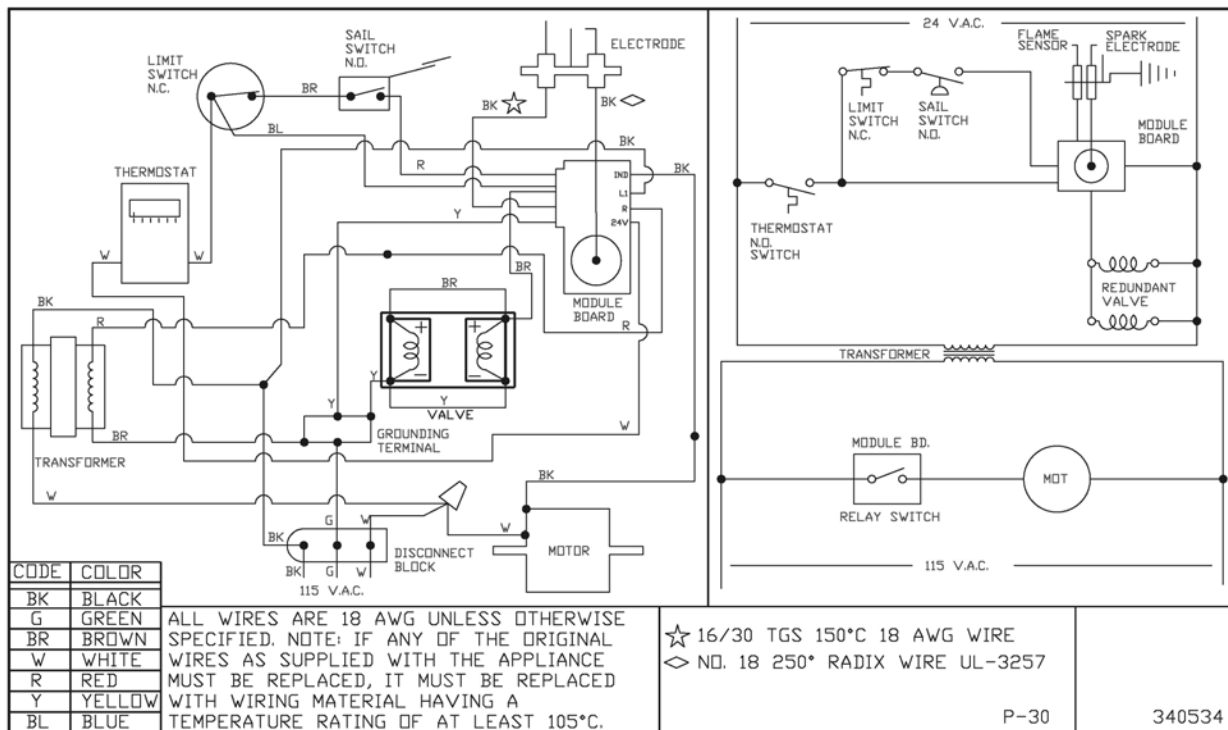

Figure 29
 Fan Control
 P-30S

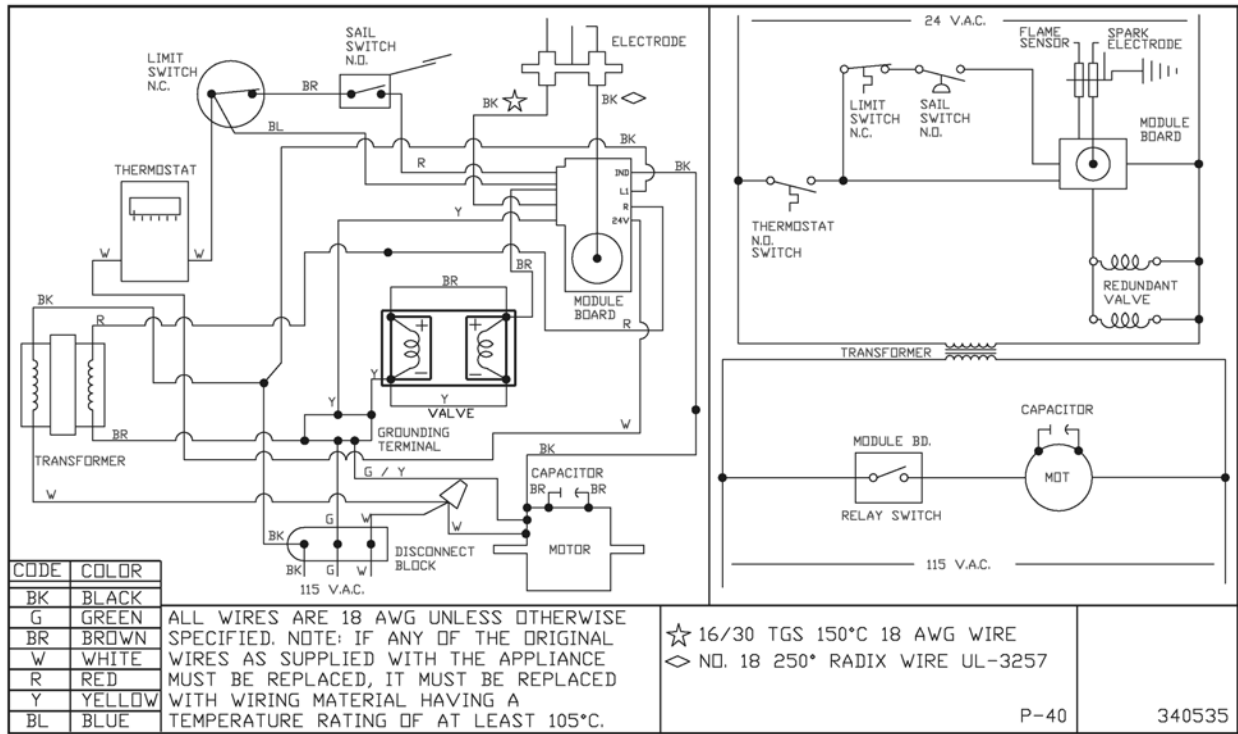

Figure 30
Fan Control Board
P-40

FURNACE REMOVAL

To replace parts or service the **SUBURBAN** family of **RV** furnaces, it is necessary to follow these steps:

DD-17DSI

1. Turn off gas and power, then disconnect gas and power supply at the furnace. Label wires as necessary.
2. Remove the vent cap assembly by removing applicable screws.
3. Remove the cabinet front two (2) screws.
4. Remove the applicable screws securing the furnace to the coach floor.
5. Remove duct from side of furnace, if equipped.
6. Remove the furnace from the cabinet area to gain access to combustion chamber and applicable parts.
7. Some parts can be accessed without removal of the complete furnace.
8. To re-install, reverse this procedure.
9. Rewire applicable wires and perform a leak test on all fittings. Perform a drop pressure test.

NT-12/16/20S

1. Turn off gas and power, then disconnect gas and power supply at the furnace. Label wires as necessary.
2. Remove the vent cap assembly by removing applicable screws.
3. Remove the cabinet front two (2) screws.
4. Remove the (1) one tie down screw securing the chamber to the cabinet.
5. Remove the furnace from the cabinet by pulling chamber outward completely to gain access to all controls and applicable parts.
6. To re-install, reverse this procedure.
7. Rewire applicable wires and perform a leak test on all fittings. Perform a drop pressure test.

NT-12/16/20SE

1. Turn off gas and power, then disconnect gas and power supply at the furnace. Label wires as necessary.
2. Remove the vent cap assembly by removing applicable screws.
3. Remove the cabinet front two (2) screws.
4. Remove the (2) two tie down screws securing the chamber to the cabinet.
5. Remove the furnace from the cabinet by pulling chamber outward completely to gain access to all controls and applicable parts.
6. To re-install, reverse this procedure.
7. Rewire applicable wires and perform a leak test on all fittings. Perform a drop pressure test.

NT-24/30/34SP and NT-40

1. Turn off gas and power, then disconnect gas and power supply at the furnace. Label wires as necessary.
2. Remove the vent cap assembly by removing applicable screws and one (1) flue retaining screw. Not applicable to NT-40.
3. Remove the cabinet front two (2) screws.
4. Remove the (2) two tie down screws securing the chamber to the cabinet.
5. Remove the furnace from the cabinet by pulling chamber outward completely to gain access to all controls and applicable parts.
6. To re-install, reverse this procedure.
7. Rewire applicable wires and perform a leak test on all fittings. Perform a drop pressure test.

FURNACE REMOVAL

SF-20/25/30/35/42, SFV-20/25/30/35/42, SH-35/42 and SHD-2542

1. Remove the vent cap assembly from the outside access door by removing applicable screws, also the four (4) screws retaining the door to the frame. Remove the door to gain access to the furnace.
2. Turn off gas and power, then disconnect gas and power supply at the furnace. Label wires as necessary.
3. Remove the (1) one tie down screw securing the chamber to the cabinet.
4. Remove the furnace from the cabinet by pulling chamber outward completely to gain access to all controls and applicable parts.
5. To re-install, reverse this procedure.
6. Rewire applicable wires and perform a leak test on all fittings. Perform a drop pressure test.

SF-20/25/30/35/42F, SFV-20/25/30/35/42F and SH-35/42F

1. Turn off gas and power, then disconnect gas and power supply at the furnace. Label wires as necessary.
2. Remove the vent cap assembly by removing applicable screws.
3. Remove the cabinet front two (2) screws.
4. Remove the (1) one tie down screw securing the chamber to the cabinet.
5. Remove the furnace from the cabinet by pulling chamber outward completely to gain access to all controls and applicable parts.
6. To re-install, reverse this procedure.
7. Rewire applicable wires and perform a leak test on all fittings. Perform a drop pressure test.

P-30S and P-40

1. Turn off gas and power, then disconnect gas and power supply at the furnace. Label wires as necessary.
2. Remove the vent cap assembly by removing applicable screws and one (1) flue retaining screw. (Not applicable to P40.)
3. Remove the cabinet front two (2) screws.
4. Remove the (2) two tie down screw securing the chamber to the cabinet.
5. Remove the furnace from the cabinet by pulling chamber outward completely to gain access to all controls and applicable parts.
6. To re-install, reverse this procedure.
7. Rewire applicable wires and perform a leak test on all fittings. Perform a drop pressure test.

SF, SH AND SHD-2542 ELECTRODE GAP SPECIFICATIONS AND POSITIONING

To assure consistent ignition of the burner, it is important for the electrode to be positioned properly over the top of the burner. When replacing the electrode, or should you be experiencing ignition type problems, the electrode should be positioned as outlined in the drawing.

1. Remove the furnace chamber assembly from the furnace cabinet following instructions listed in the installation manual.
2. Remove the burner access door. Manifold assembly will have to be removed at the valve. Remove the burner from the combustion chamber by removing six (6) screws which attach the burner to the chamber and air baffles (plates). Remove top air baffle and clip.
3. Locate the lance in relation to the burner ports for electrode positioning by:
 - a. Shine a flashlight into the burner venturi as illustrated (be sure the flashlight lens is against the end of the burner).
 - b. Light will reflect off the lance in the venturi of the burner and shine through a position of the two (2) rows of burner ports in the top of the burner.
 - c. Using a black felt-tip pen, mark a line along top of burner $3/16$ " from back of lance and parallel with lance. Make an additional mark indication center line of the lance. (See illustration). Both marks will be used later as reference marks; therefore, keep lines thin.
4. Reassemble the burner into the chamber. Be sure the air baffles (plates) are positioned as removed. Mount center clip in place.
5. Adjust electrode so the electrode probe is positioned along the marked center line of the burner lance and the tip of the electrode terminates $3/16$ " from the back of the lance (at the line marked in Step 3C). (See illustration).
6. **IMPORTANT:** Be sure electrode probe maintains a $1/8$ " spark gap over the burner as illustrated.
7. Reinstall burner access door and reconnect manifold. Manifold must be checked for leaks with unit operating, before installing in cabinet. Reinstall furnace into the cabinet following the instructions in the installation manual. Check all gas connections for leaks using proper leak test solution.

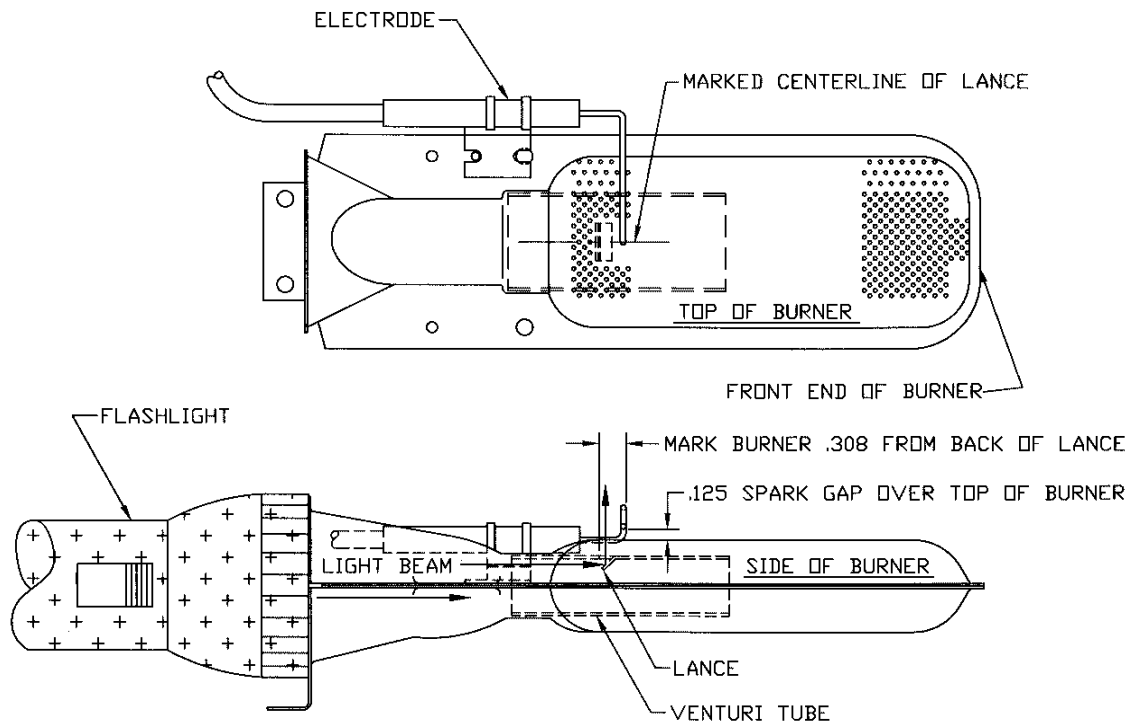
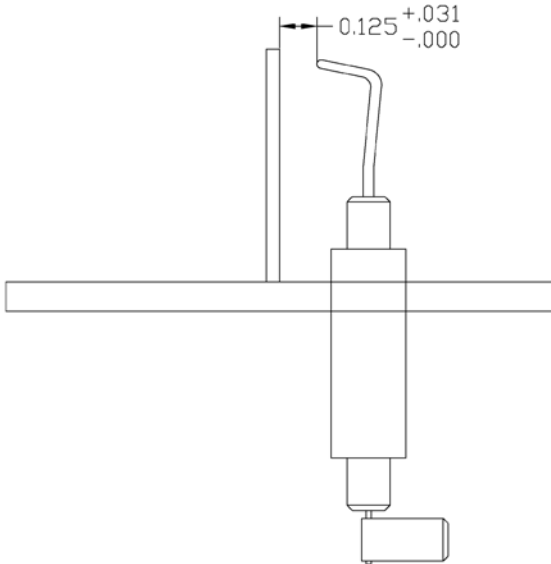

Figure 31

NT ELECTRODE GAP SPECIFICATIONS AND POSITIONING

To assure consistent ignition of the burner, it is important for the electrode to be positioned properly over the top of the burner. When replacing the electrode, or should you be experiencing ignition type problems, the electrode should be positioned as outlined in the drawing.



1. 1/8" spark gap between electrode and ground.
2. Maintain electrode position of 3/16" over burner ports.

Figure 32
LOCAL FLAME SENSE

PARK MODEL ELECTRODE GAP SPECIFICATIONS AND POSITIONING

To assure consistent ignition of the burner, it is important for the electrode to be positioned properly over the top of the burner. When replacing the electrode, or should you be experiencing ignition type problems, the electrode should be positioned as outlined in the drawing.

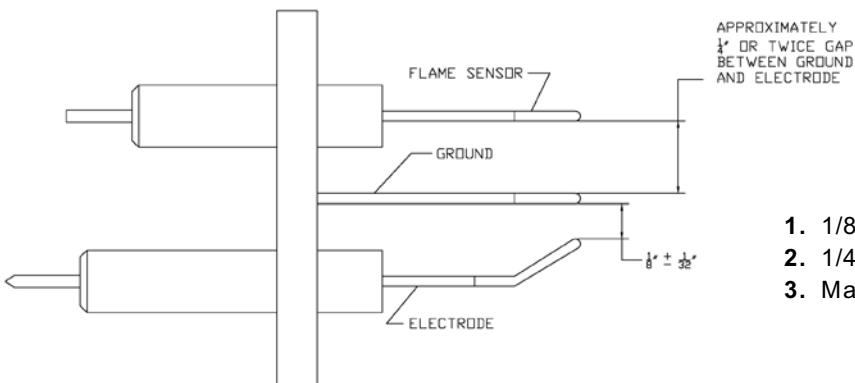

1. 1/8" spark gap between electrode and ground.
2. 1/4" spark gap between ground and flame sensor.
3. Maintain electrode position of 3/16" over burner ports.

Figure 33
REMOTE FLAME SENSE

MAINTENANCE

Preventative maintenance is essential if an RV owner is to have reliable, safe operation of his furnace. Two important areas to watch closely in order to assure safe, reliable operation are the venting and the main burner.

An obstruction in the vent or main burner will reduce the combustion air which results in incomplete combustion. Whenever incomplete combustion occurs, the by-products are carbon monoxide (CO) and soot. If the furnace outside exhaust vent shows black soot forming, the furnace should not be operated until the problem is corrected. Two common causes are:

1. Restriction in the vent or furnace intake (screens, wasp nests, tape).
2. Dirty burner.

If operation of the furnace continues under these conditions, it could result in serious injury to the occupants of the RV or even death.

Cleaning of the main burner and an inspection of the venting system should be done at least once a year, preferably just before the beginning of the heating season. Some RV owners and service personnel have the false assumption that if a furnace has not been used, it will not require cleaning. **NOT SO!** A furnace which has not been used for some time could be more in need of cleaning than a furnace which has been used extensively.

Dust and lint should be removed from the room air blower wheel and sail switch. A build up of dust and lint on the blower wheel can cause the motor to drag and not generate enough air flow to engage the sail switch. Dust accumulation on the sail switch will restrict the travel of the actuator arm to where the air flow across the paddle will not sail it in and complete the valve circuit.

A yearly inspection should be made of all gaskets on the furnace. If any gaskets show signs of leakage or deterioration, they must be replaced.

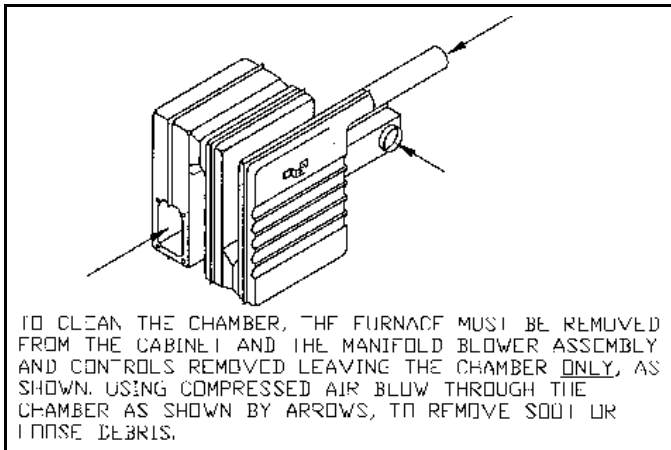

Figure 34

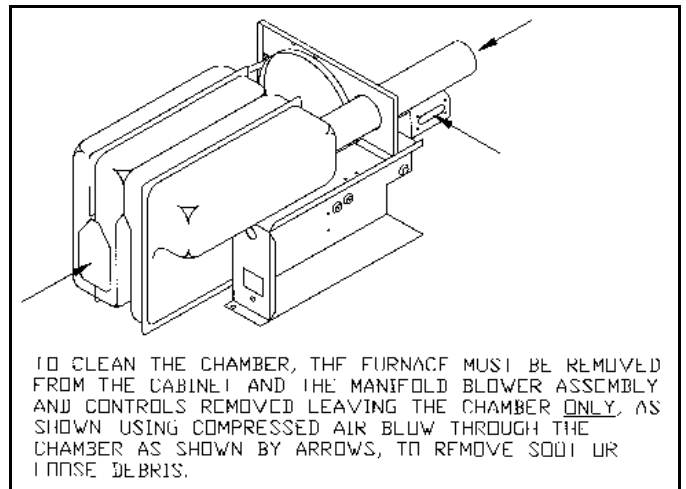

Figure 35

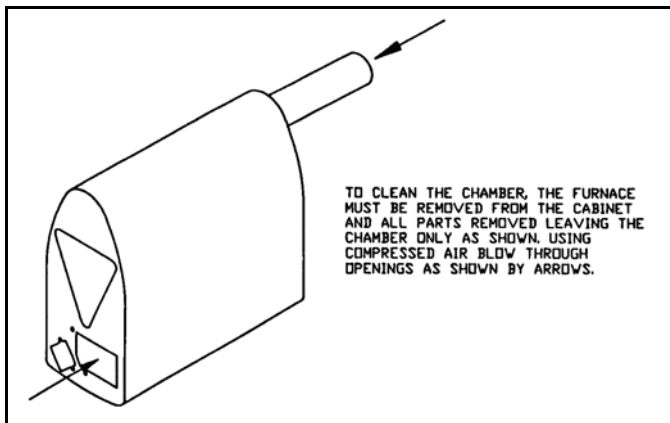

Figure 36

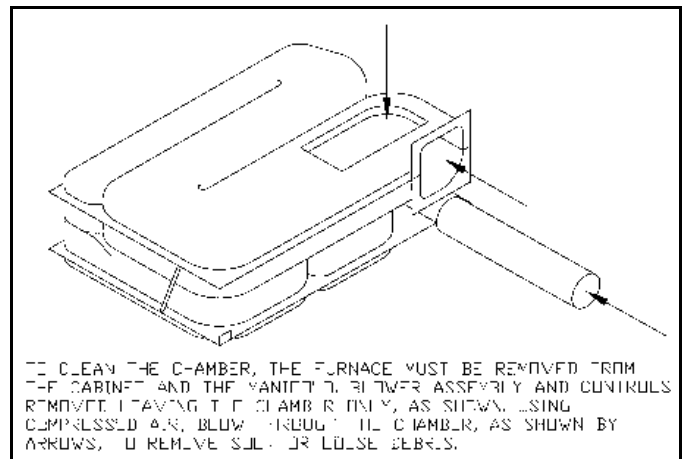

Figure 37

CAUTIONS & SAFETY INFORMATION

1. Never use a battery charger to power or test an electronic ignition furnace as they sometimes provide more than 14.5 DC Volts that could damage the module board.
2. Never operate the furnace with the electrode wire disconnected nor with the electrode assembly removed from the furnace.
3. Never use a screwdriver on any part of the electrode assembly while the furnace is in operation.
4. Be certain that the spark from the electrode never reaches the flame sensor portion of the electrode assembly on remote sense units.
5. Install the furnace so electrical components and connections are protected from water.
6. Wire the furnace direct to the battery when possible.
7. Use two wrenches on gas fittings when tightening gas connections.
8. Verify voltage of furnace, do not use 120 volt AC with 12 volt DC.
9. Do not modify the furnace in any way.
10. Do not vent the furnace to an outside enclosed porch area or where the vent is covered or obstructed.
11. Always meet or exceed minimum duct requirements. Also meet the minimum return air requirements.
12. Furnace must be installed and vented correctly. Refer to the Installation Manual for the specific model furnace.
13. Do not install aftermarket components.



SUBURBAN MANUFACTURING COMPANY
676 Broadway Street
Dayton, Tennessee 37321
423-775-2131
Fax: 423-775-7015
www.rvcomfort.com
E-mail: info1@suburbanmfg.com